

THE
SAGAMORE
RESIDENCE

AUGUST, 01, 2023

BY
STUDIO
MUNGE

100% SUITE SCHEMATIC DESIGN PRESENTATION

100% Schematic Design

table of contents

1. kitchen
2. large kitchen
3. ensuite
4. secondary bathroom
5. powder room

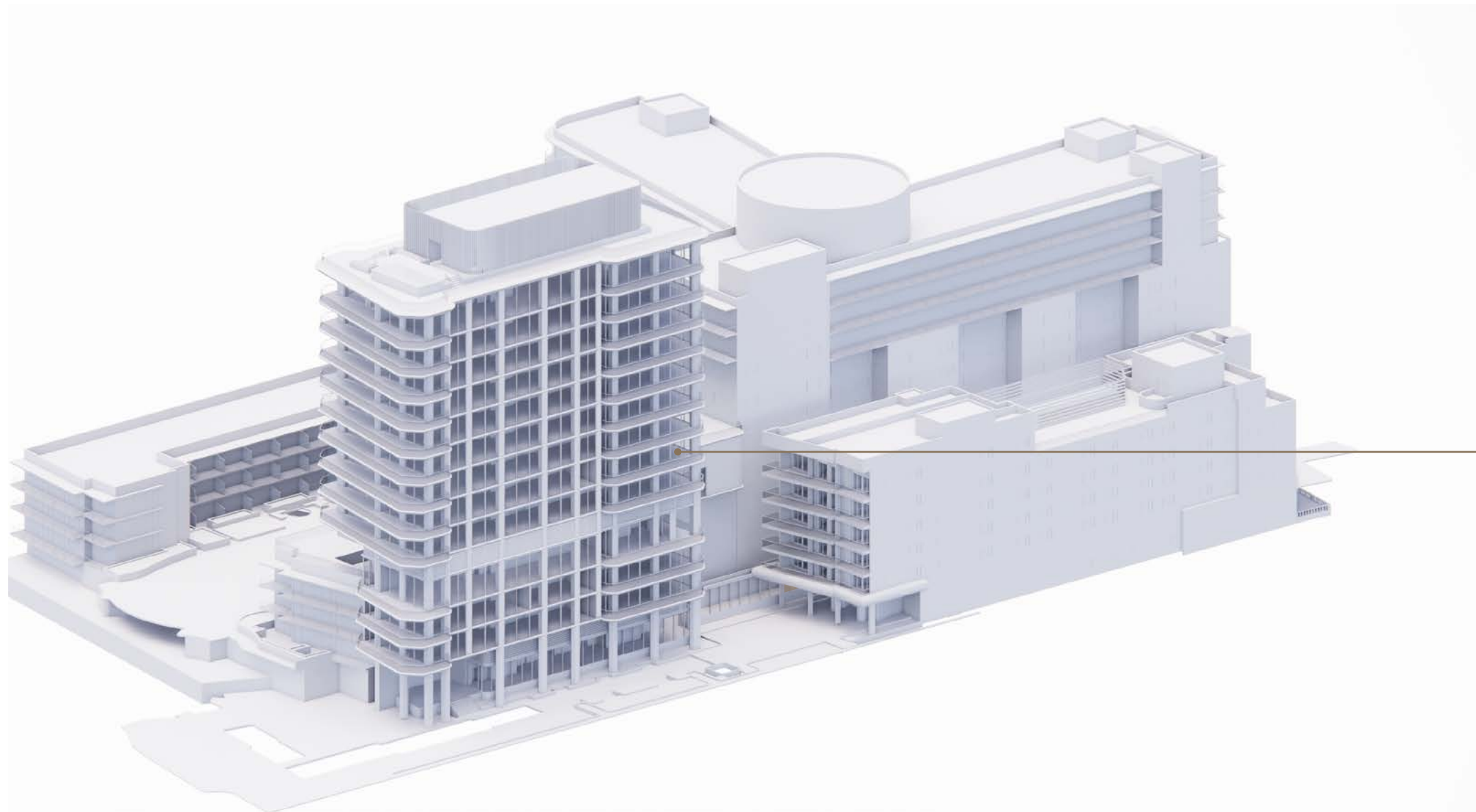

RESIDENTIAL SUITES

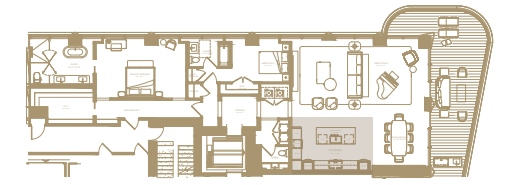

L7 NORTH EAST SUITE

KITCHEN PLAN

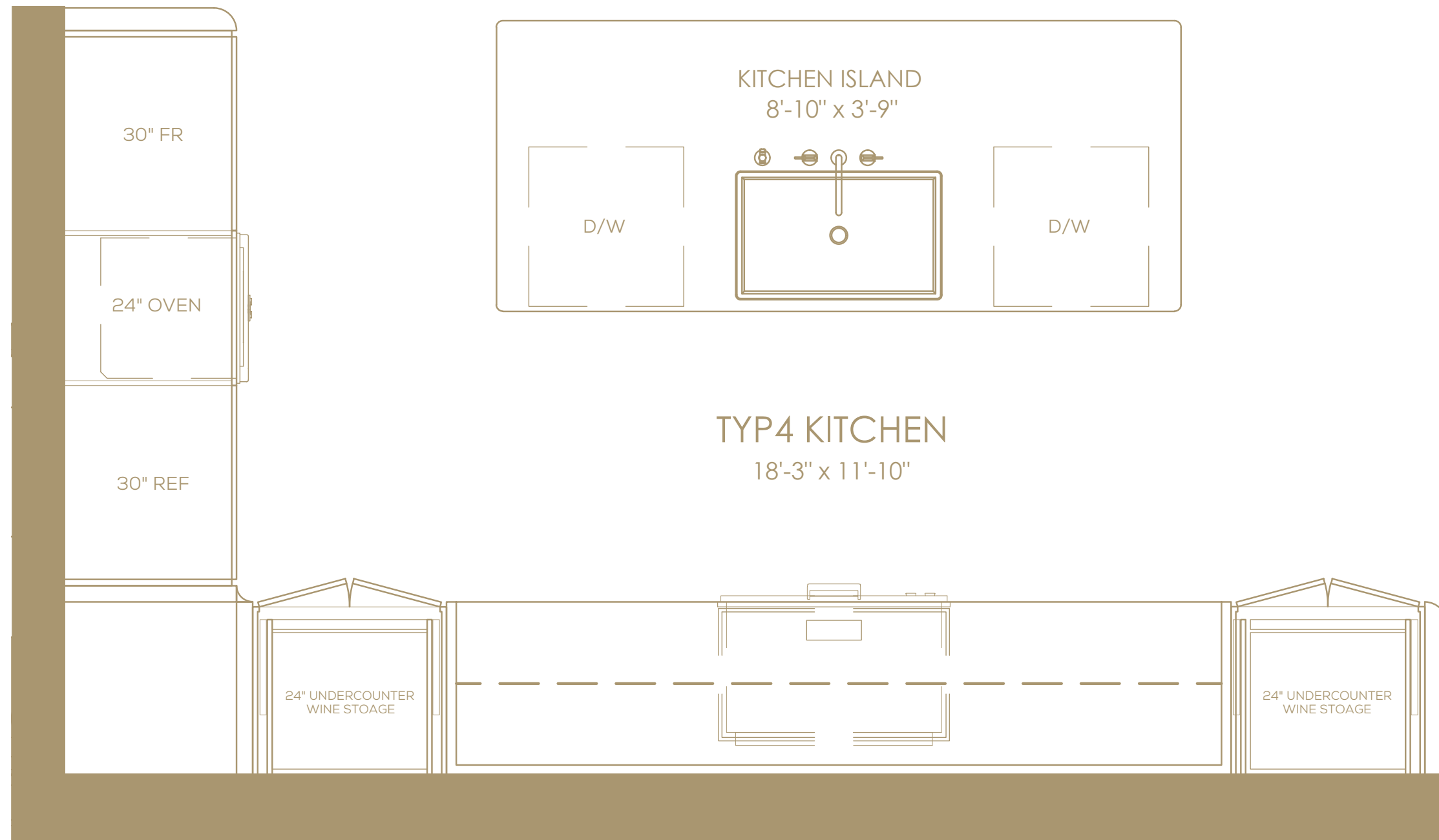



L7 NORTH EAST SUITE KITCHEN OPEN (STONE BACKSPLASH)



L7 NORTH EAST SUITE KITCHEN



L7 NORTH EAST SUITE KITCHEN



L7 NORTH EAST SUITE KITCHEN



L7 NORTH EAST SUITE KITCHEN



L7 NORTH EAST SUITE APPLIANCES

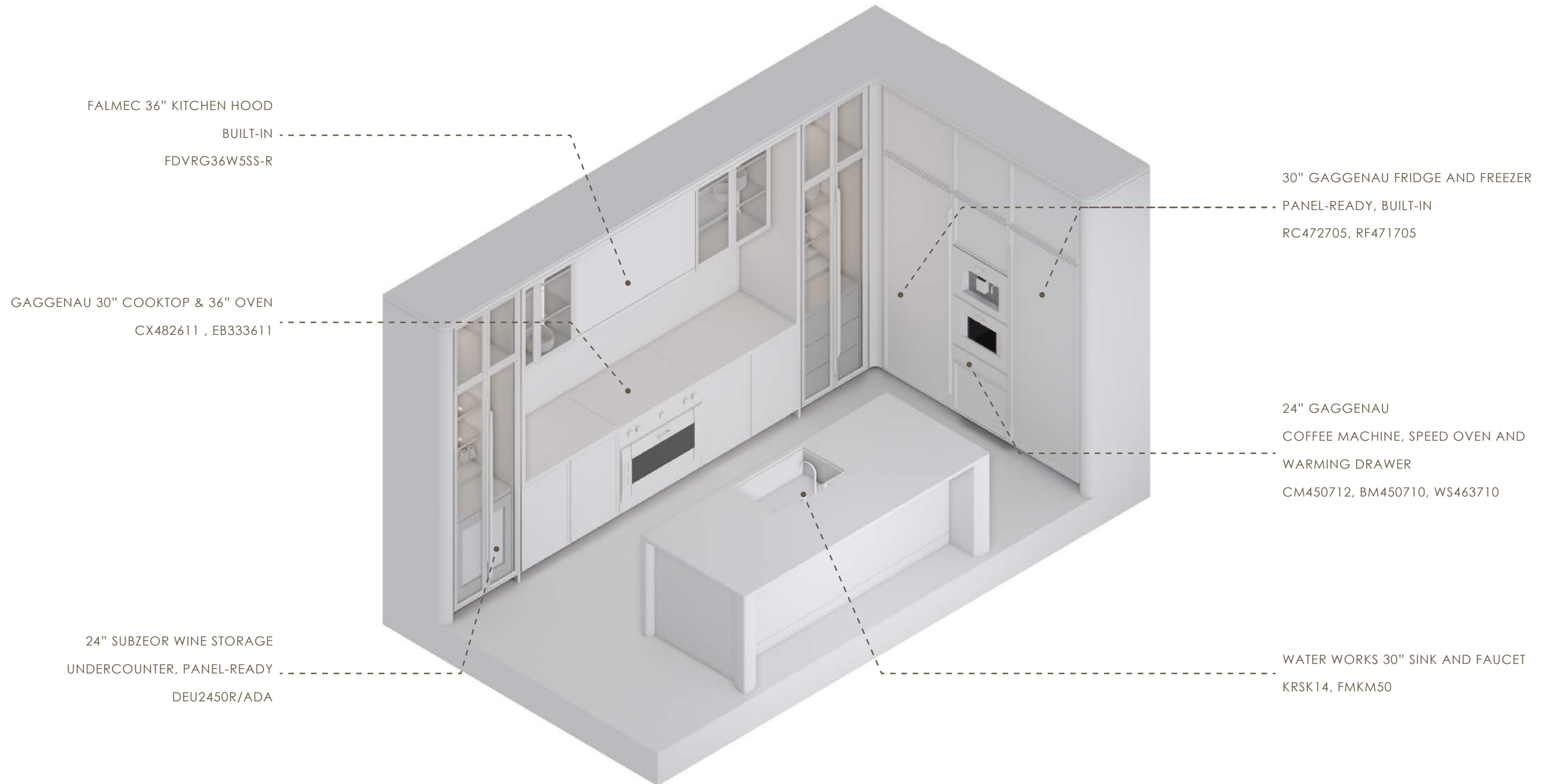

FALMEC 36" KITCHEN HOOD
BUILT-IN
FDVRG36W5SS-R

GAGGENAU 30" COOKTOP & 36" OVEN
CX482611 , EB333611

24" SUBZEOR WINE STORAGE
UNDERCOUNTER, PANEL-READY
DEU2450R/ADA

30" GAGGENAU FRIDGE AND FREEZER
PANEL-READY, BUILT-IN
RC472705, RF471705

24" GAGGENAU
COFFEE MACHINE, SPEED OVEN AND
WARMING DRAWER
CM450712, BM450710, WS463710

WATER WORKS 30" SINK AND FAUCET
KRSK14, FMKM50

L12-13 EAST SUITE

KITCHEN PLAN OPT1

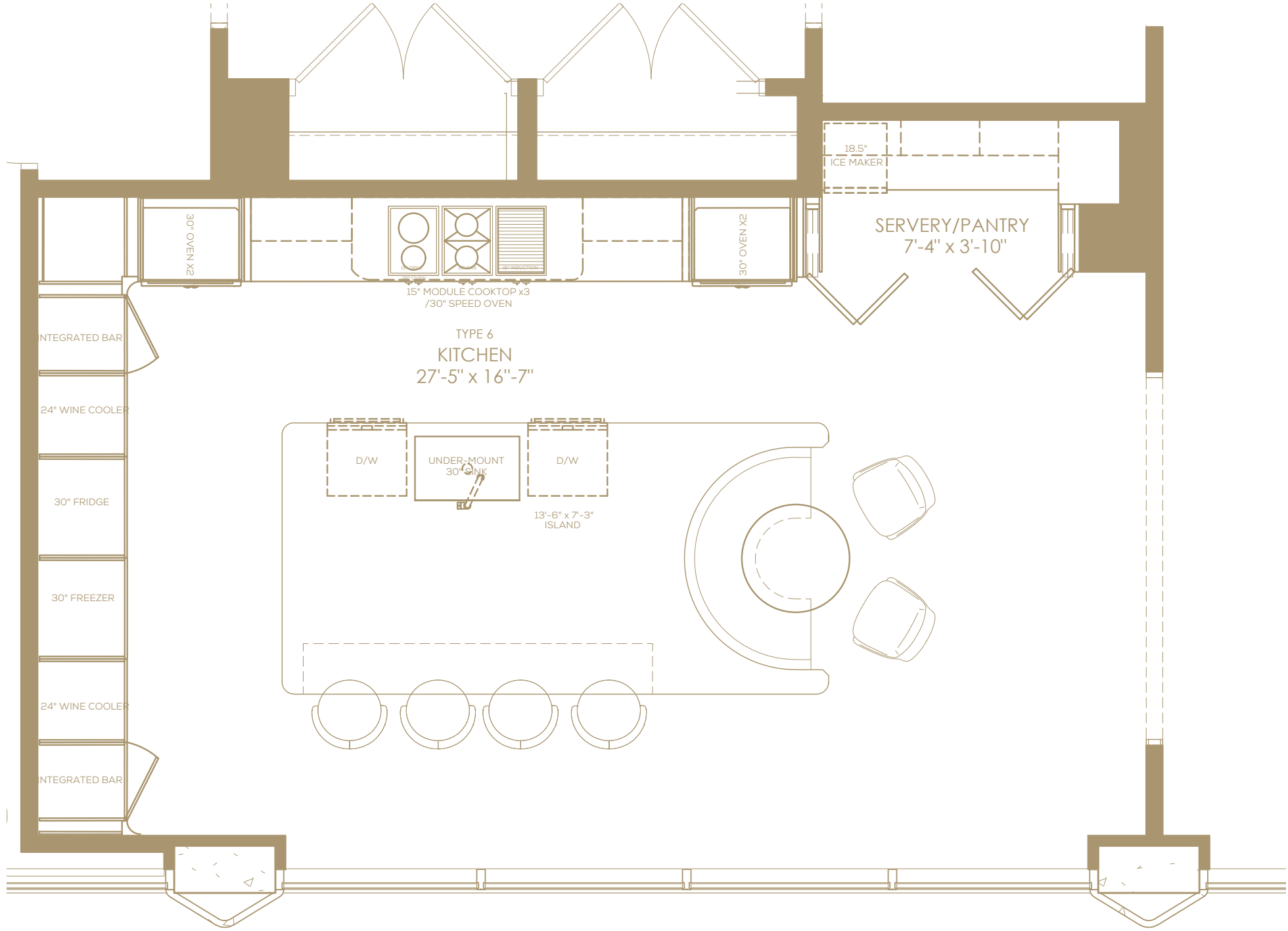
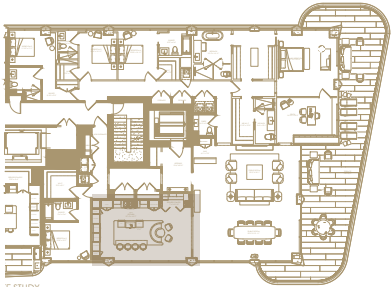









L12-13 EAST SUITE

KITCHEN PLAN OPT2

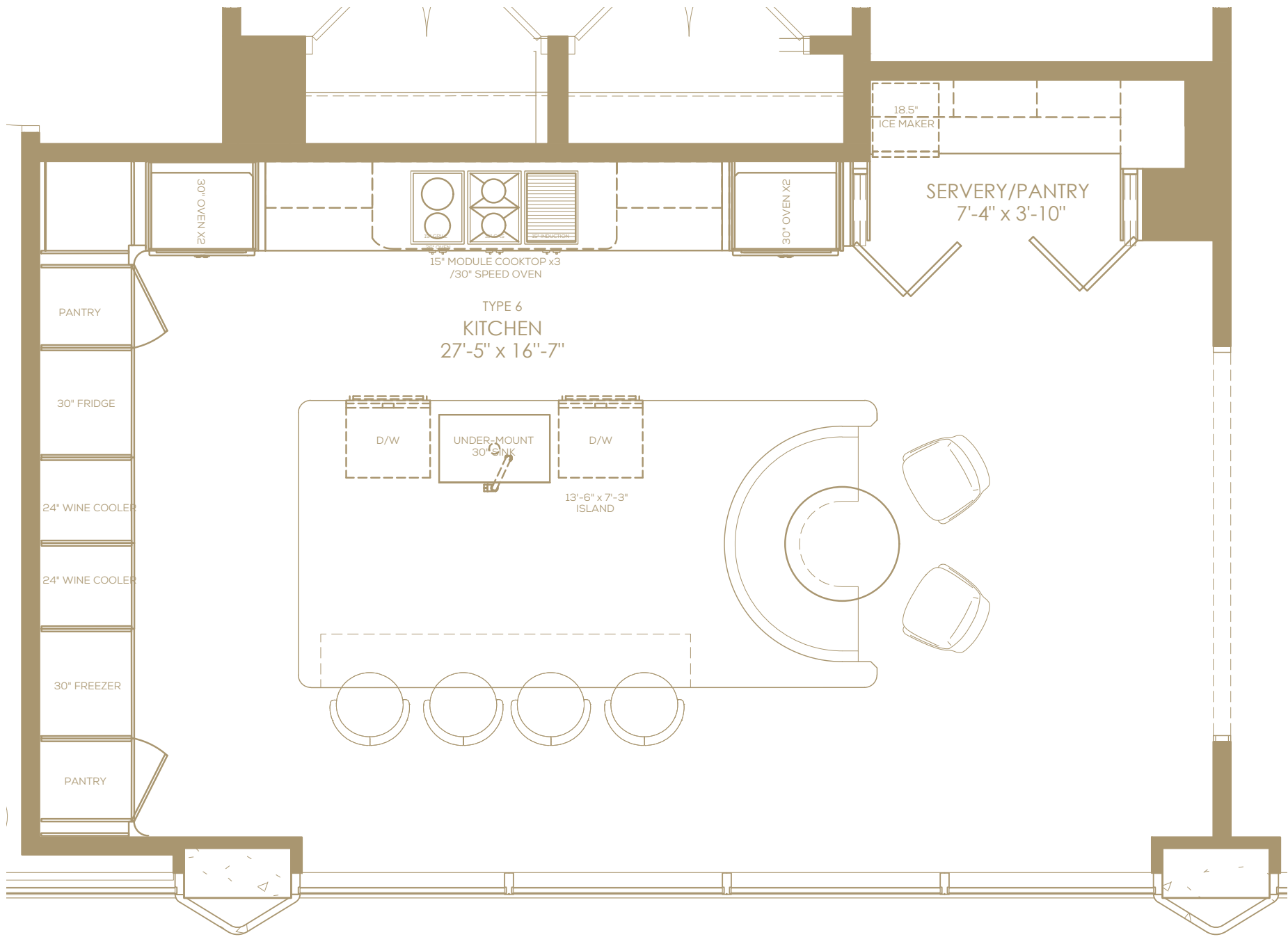
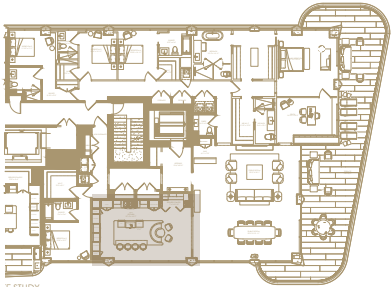









L12-13 WEST SUITE

PRIMARY ENSUITE PLAN

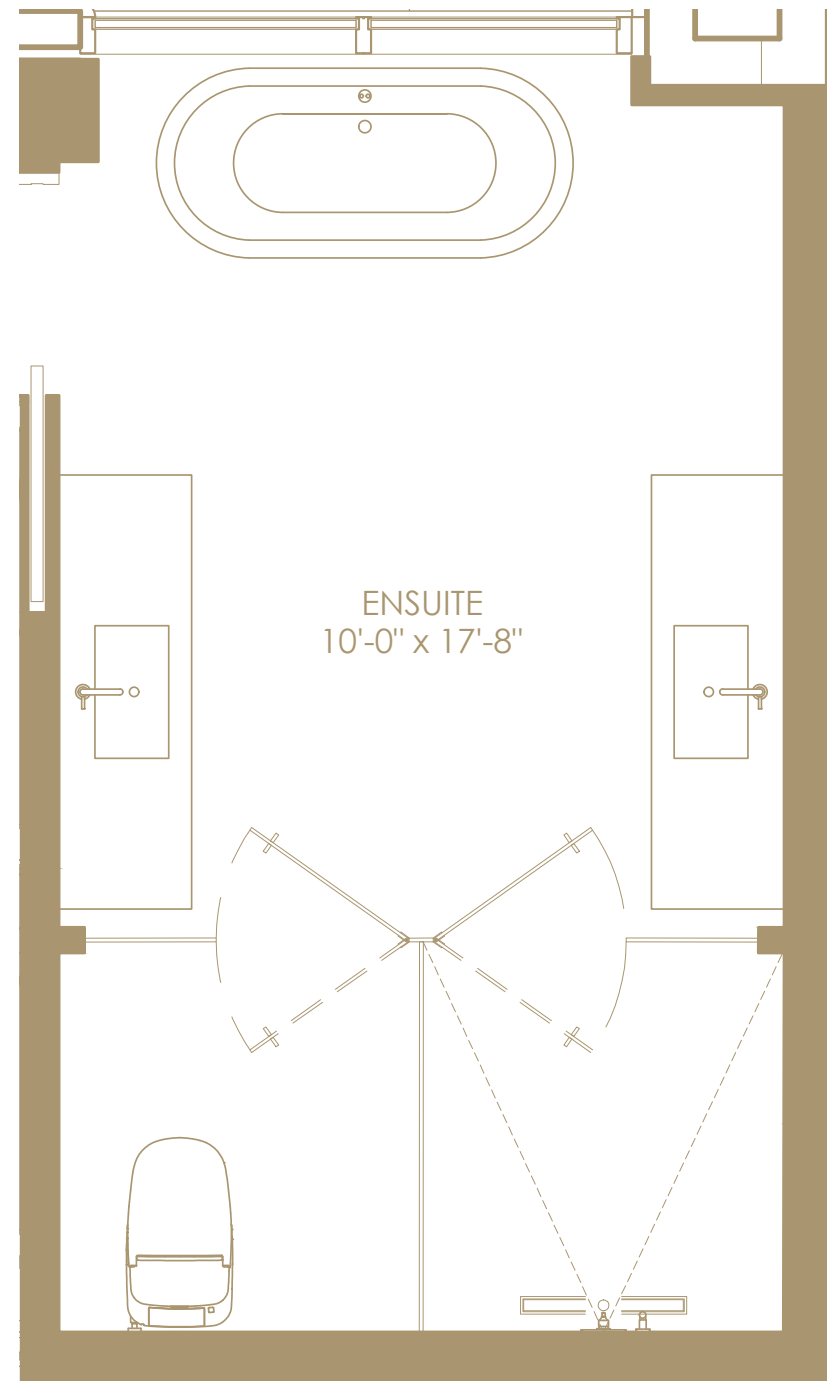





L12-13 WEST SUITE PRIMARY ENSUITE





L12-13 WEST SUITE

SECONDARY ENSUITE

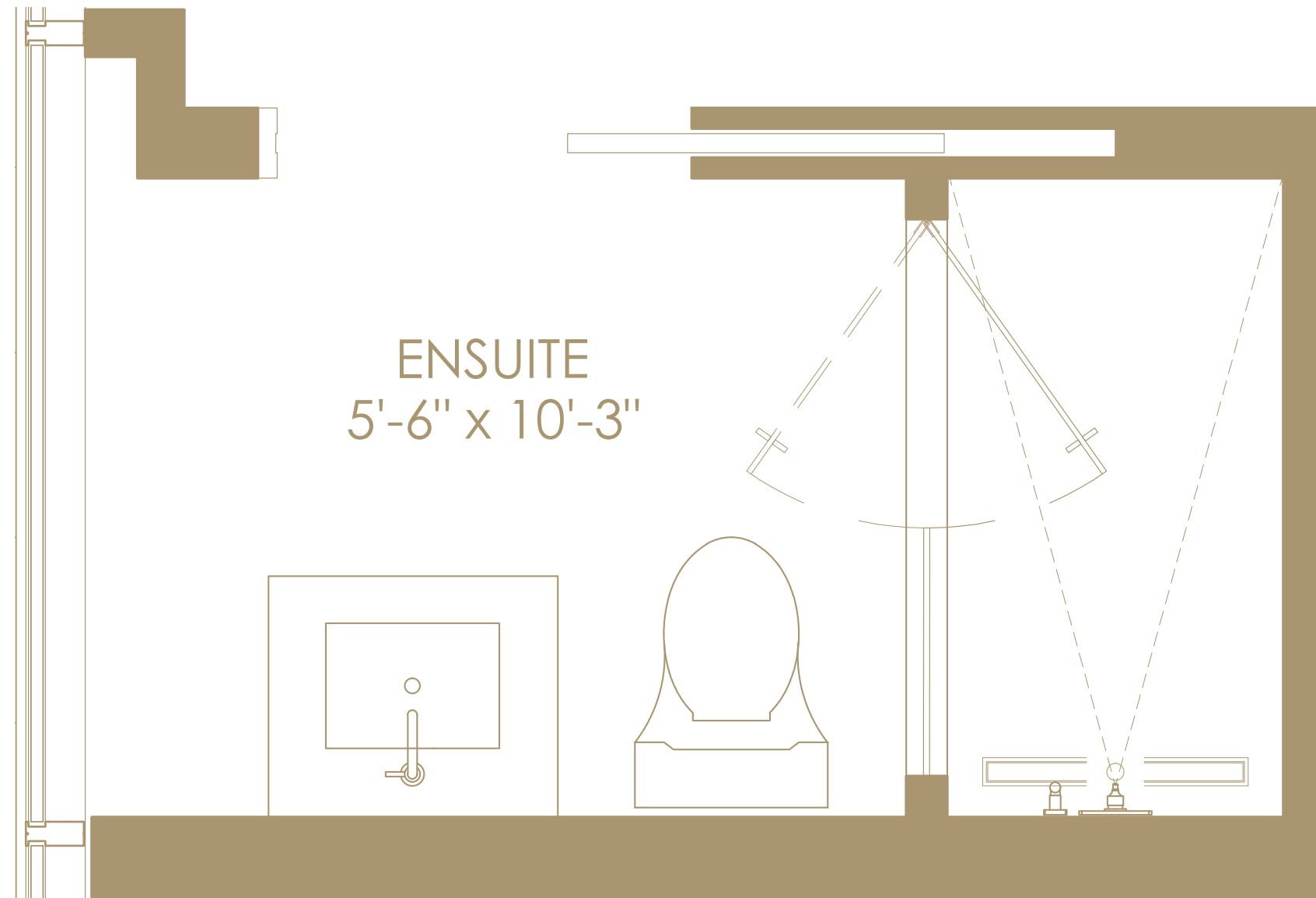





L7 NORTH EAST SUITE

POWDER ROOM

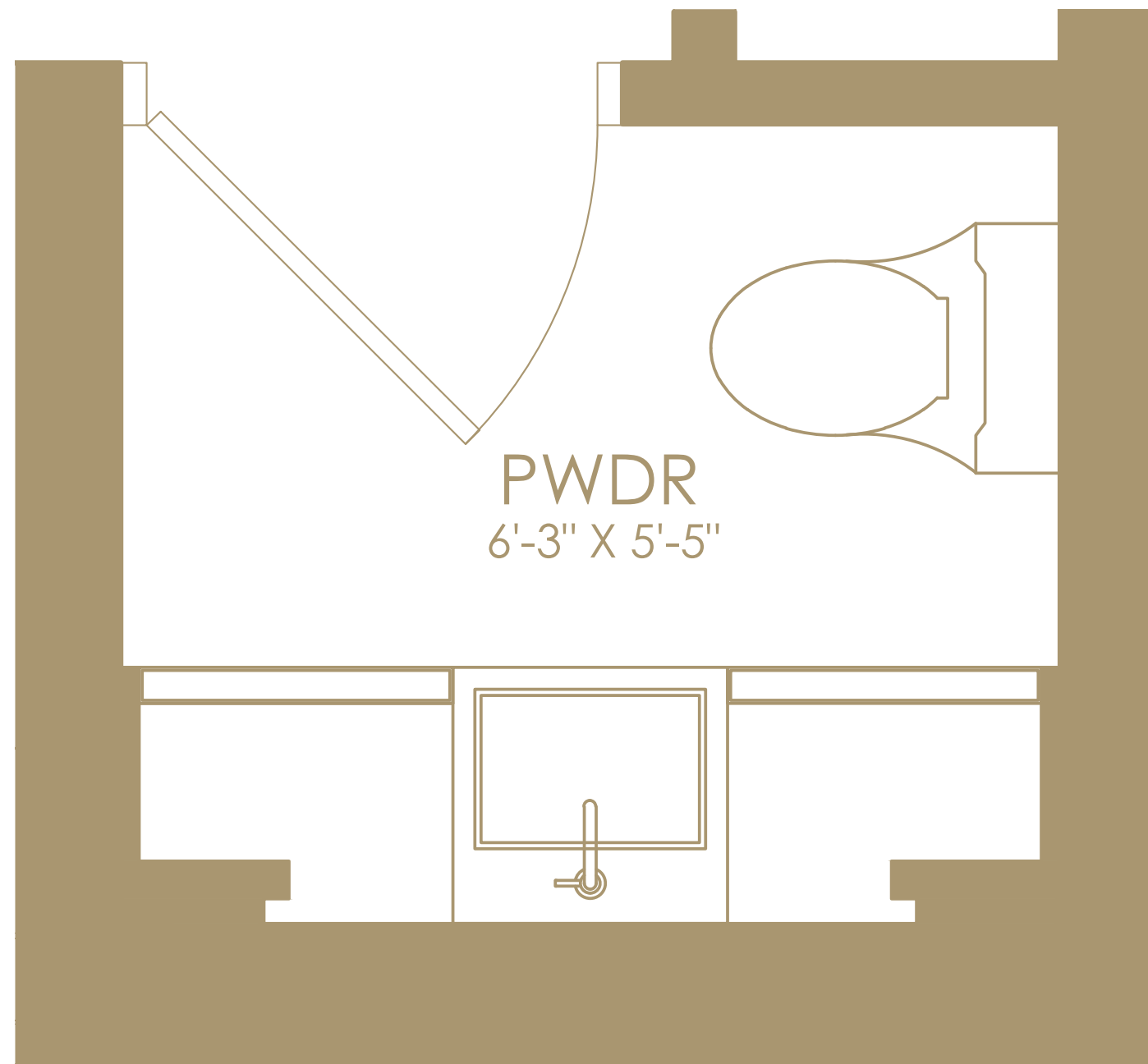





SCHEMATIC DESIGN
summary



