

# Natasha

THE RESIDENCES

TYPICAL SUITE CONCEPT DESIGN PROGRESS - FEBRUARY 26, 2021  
263 ADELAIDE ST W, TORONTO ON

## WE DO MORE THAN INTERIOR DESIGN.

We think beyond walls and floors and imagine the shared experience.

## WE CREATE MORE THAN PRETTY PICTURES.

Studio Munge creates the energy that audiences respond to and brings businesses to life.

Since 1997, we have been positively impacting the communities and cities we design in.

## WE IMAGINE EXCITING SPACES.

Spaces that people want to be a part of. We have a keen insight, foresight, and passion for the flow of design that brings a space to life.

KITCHEN ATMOSPHERE

NATASHA KITCHEN AND DINING CONCEPT



STRONG CONTRAST



CLEAN LINES



ATTENTIVE



SIMPLIFIED



REFINED

NATASHA KITCHEN AND DINING CONCEPT



MULTI-FUNCTIONAL



FLIP-DOWN



ROTATE-OUT



ENGAGING

TYPICAL SUITE SMART KITCHEN  
FUNCTIONAL UNITS

NATASHA RESIDENCE

## KITCHEN TYPE & PACKAGE

TYPICAL SUITE KITCHEN TYPE 01

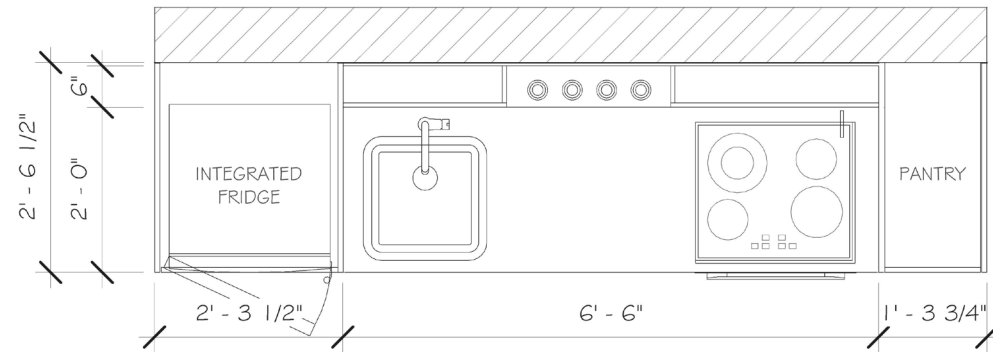

PLAN  
SCALE: 3/4"=1'-0"

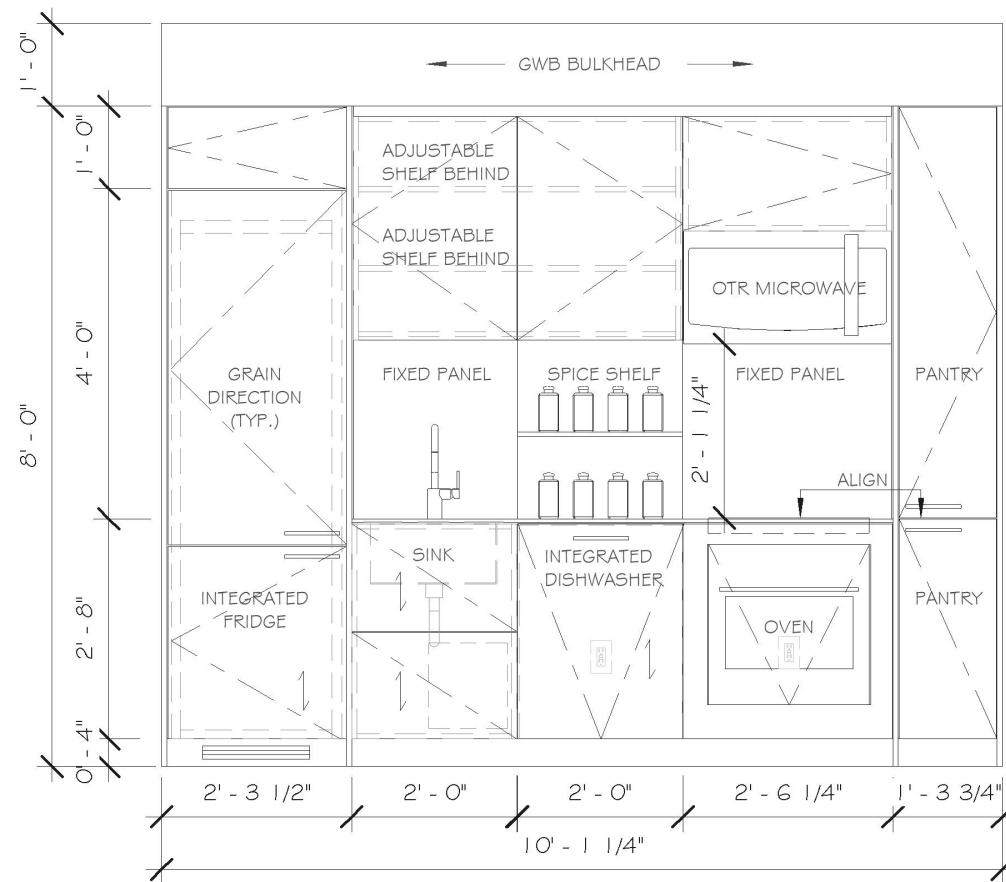

FRONT ELEVATION  
SCALE: 3/4"=1'-0"



3D VIEW KITCHEN TYPE 01  
PANTRY + SPICE STORAGE

TYPICAL SUITE KITCHEN TYPE 02

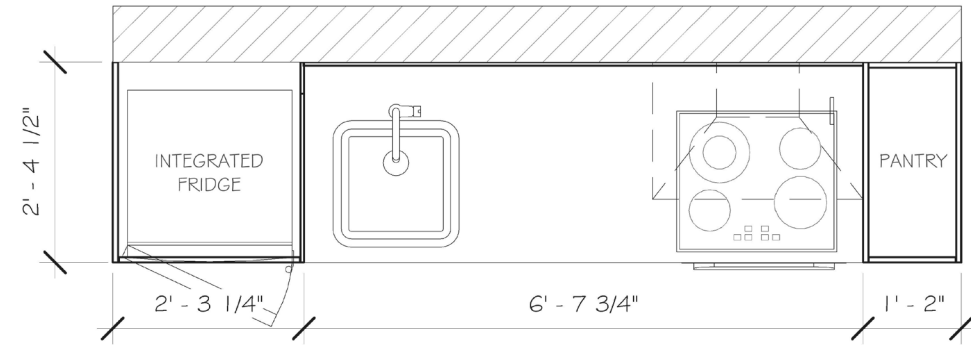

PLAN  
SCALE: 3/4"=1'-0"

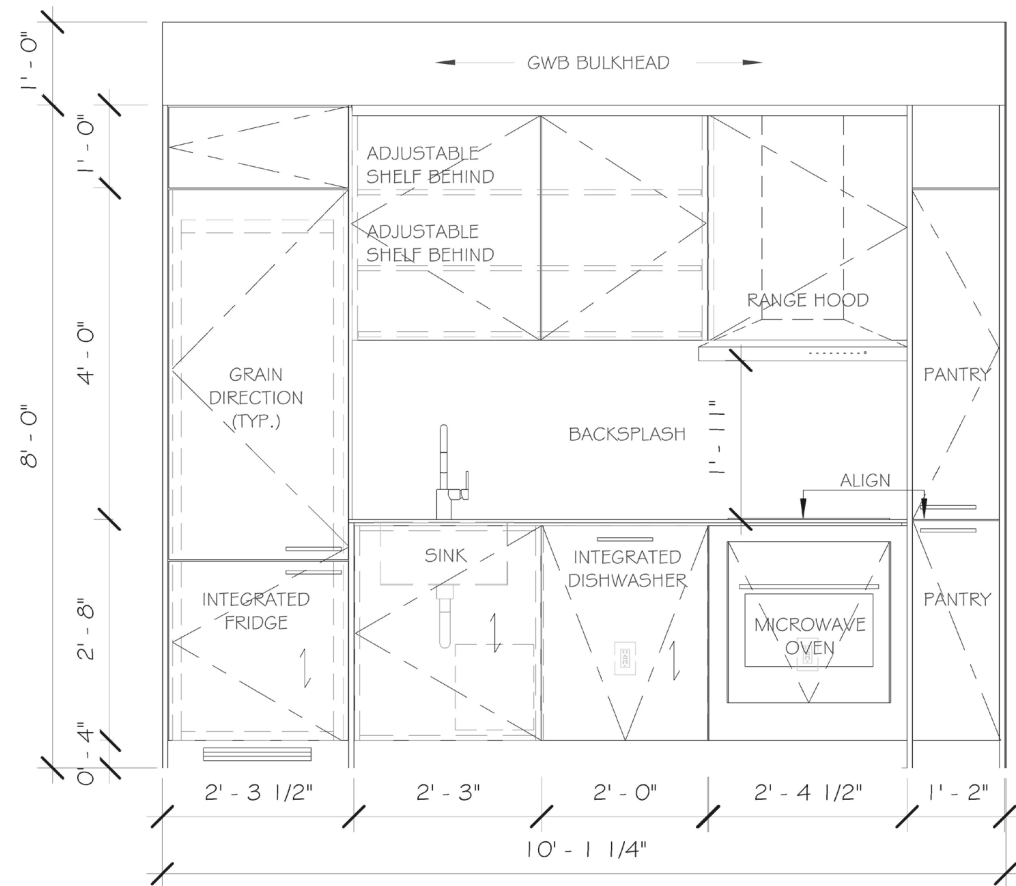

FRONT ELEVATION  
SCALE: 3/4"=1'-0"



3D VIEW KITCHEN TYPE 02  
PANTRY WITH 3 DIFFERENT TYPES OF COMPARTMENTS



TYPICAL SUITE KITCHEN TYPE 02 PACKAGE



KITCHEN STANDARD  
PACKAGE 02



PANTRY ADD-ON  
PULL-OUT BAR OR  
STORAGE



FULL PACKAGE  
KITCHEN + BAR/STORAGE UNIT

TYPICAL SUITE KITCHEN TYPE 02 PACKAGE



KITCHEN STANDARD  
PACKAGE 02



ADD-ON 14"W  
UPGRADE



FULL PACKAGE  
KITCHEN + WORK

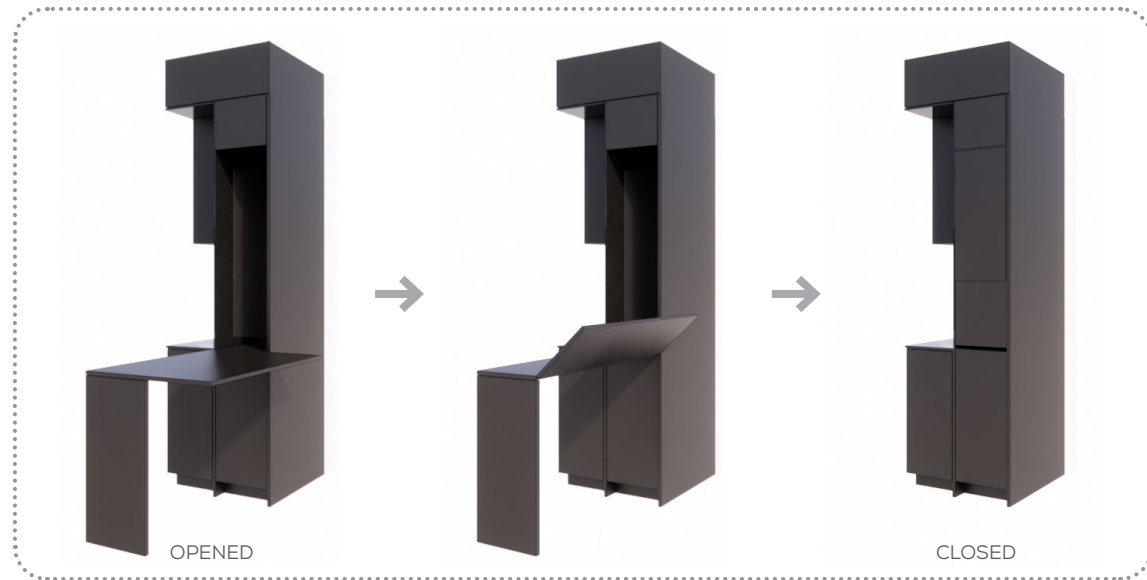

ASSEMBLY  
KITCHEN + WORK

TYPICAL SUITE KITCHEN TYPE 03 PACKAGE

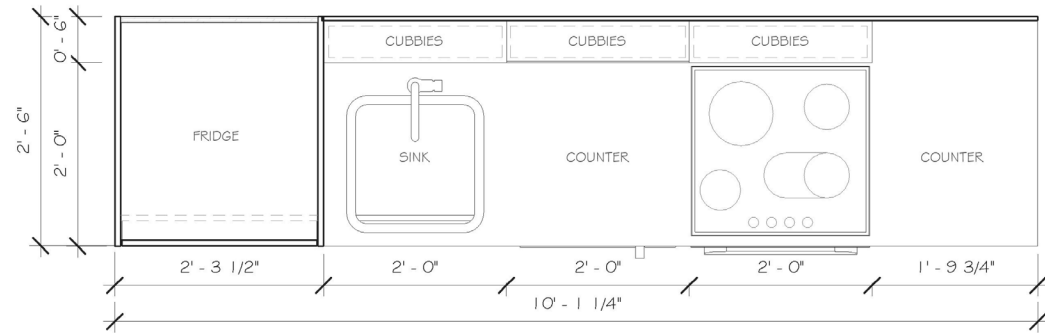

PLAN  
SCALE: 3/4"=1'-0"

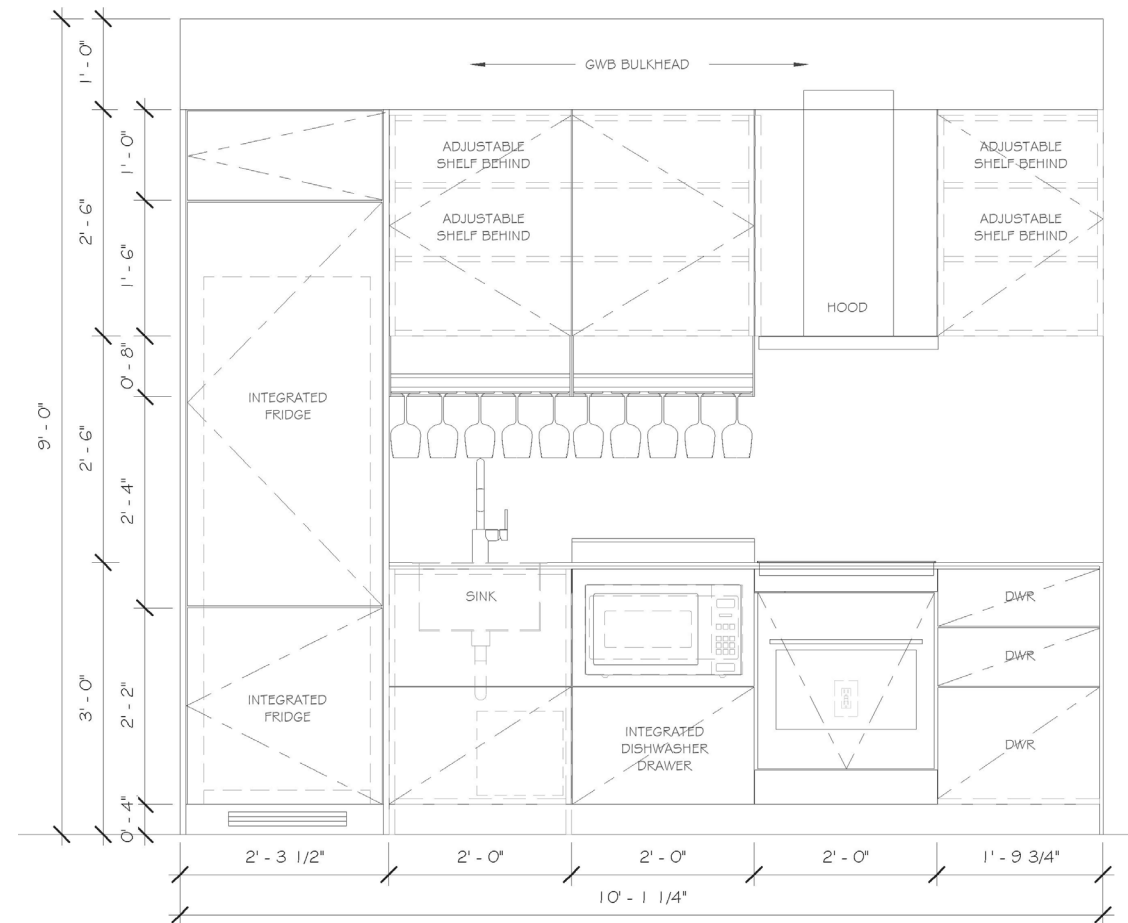

FRONT ELEVATION  
SCALE: 3/4"=1'-0"



HARDWARE OPTIONS  
UPGRADE

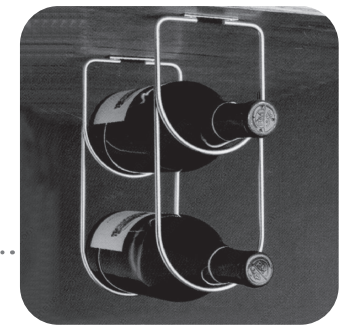

BOTTLE RACK  
RICHIEU



WINE GLASS RACK  
RICHIEU | WINEVIEW

TYPICAL SUITE KITCHEN TYPE 3  
OPEN CUBBIES + WINE RACK

NATASHA RESIDENCE

TYPICAL SUITE WASHROOM

TYPICAL SUITE WASHROOM



TYPICAL SUITE WASHROOM

THANK YOU