

E BY EQUINOX

UPPER EAST SIDE, MANHATTAN

SCHEMATIC DESIGN

THURSDAY, FEBRUARY 22, 2018

STUDIO
MUNGE

THE UPPER EAST SIDE DESERVES THE ULTIMATE IN EXCLUSIVITY.

LOCAL CONTEXT THE UPPER EAST SIDE, MANHATTAN



ARTFUL INSPIRATION



AN EXTRAORDINARY CITYSCAPE



INTIMATE APPEAL



THOUGHTFUL EXPERIENCES

E IS FOR THOSE WHO CRAVE A DEEPER INSPIRATION AND HIGHER TRANSFORMATION.

A PERSONAL VISIONARY

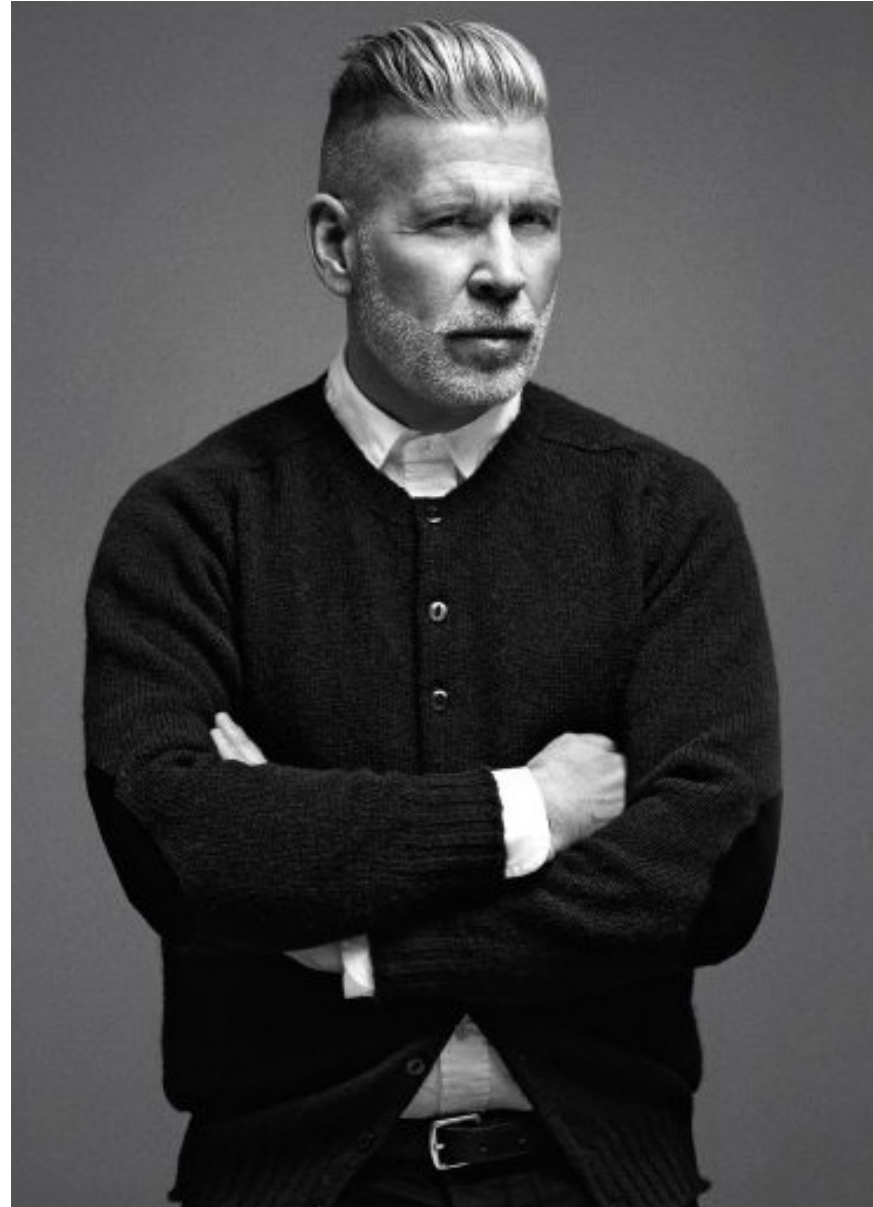

AN ARBITER OF HIGH STYLE



A CONNOISSEUR OF LIVING WELL

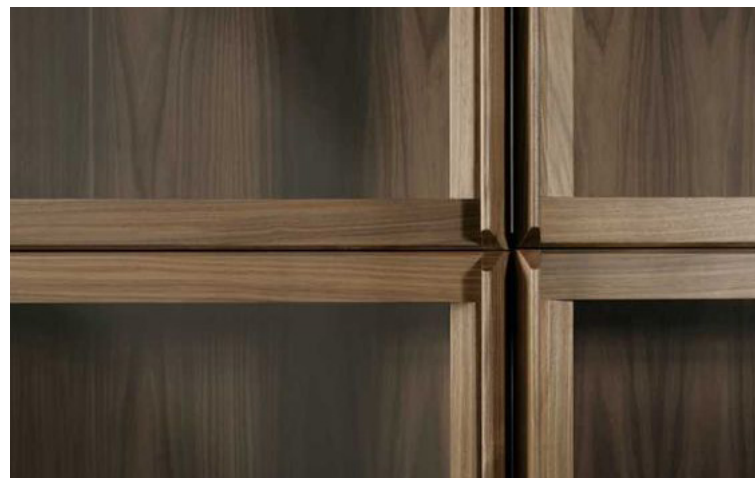

THE ART OF LIVING

This E by Equinox draws influence from life in the Upper East Side. A neighborhood characterized by its luxury residences, celebrated museums and exclusive inner circle. With its unique residential approach, this club enhances its personalized fitness training with a truly masterful interior experience.

RESIDENTIAL FAMILIARITY

INTIMATE LUXURIES

THOUGHTFUL DETAILS

THE GUEST WALKTHROUGH:

Exploring the guests' journey through the lens of interior design across all touchpoints:



01 AN EXCLUSIVE ARRIVAL
ENTRANCE FOYER

02 A SPACE TO NOURISH
OPEN KITCHEN AND RETAIL

03 A SPACE TO GATHER
LIVING ROOM

04 A SPACE TO CLEANSE
MASTER BATH AND SPA

05 A SPACE FOR TRANSFORMATION
PERSONAL FITNESS STUDIO

01 AN EXCLUSIVE ARRIVAL ENTRANCE FOYER

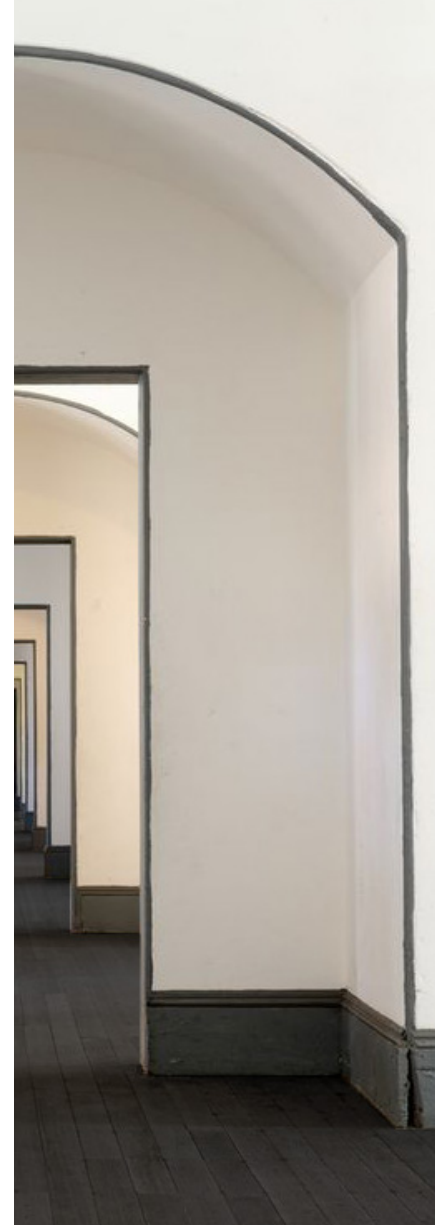

INVITING FORMS

RESIDENTIAL

CENTRALLY FOCUSED

GRANDEUR

FAMILIAR DETAILS

ELEVATION EXTERIOR FACADE



1 EXTERIOR FACADE ELEVATION
N.T.S.

PLANNING GROUND FLOOR PLAN LAYOUT

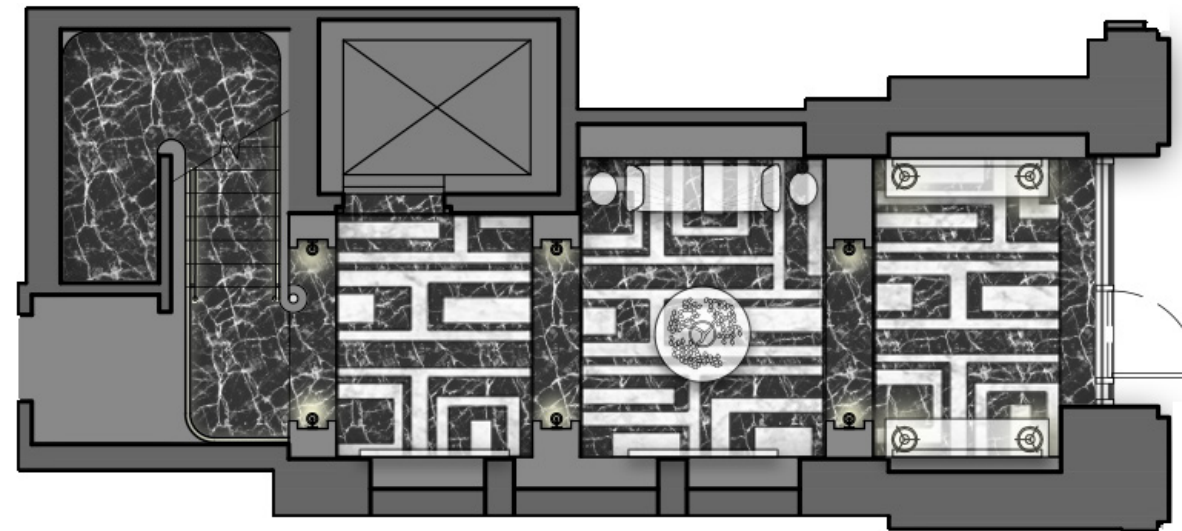

GROUND FLOOR PLAN

PLANNING GROUND FLOOR REFLECTED CEILING PLAN

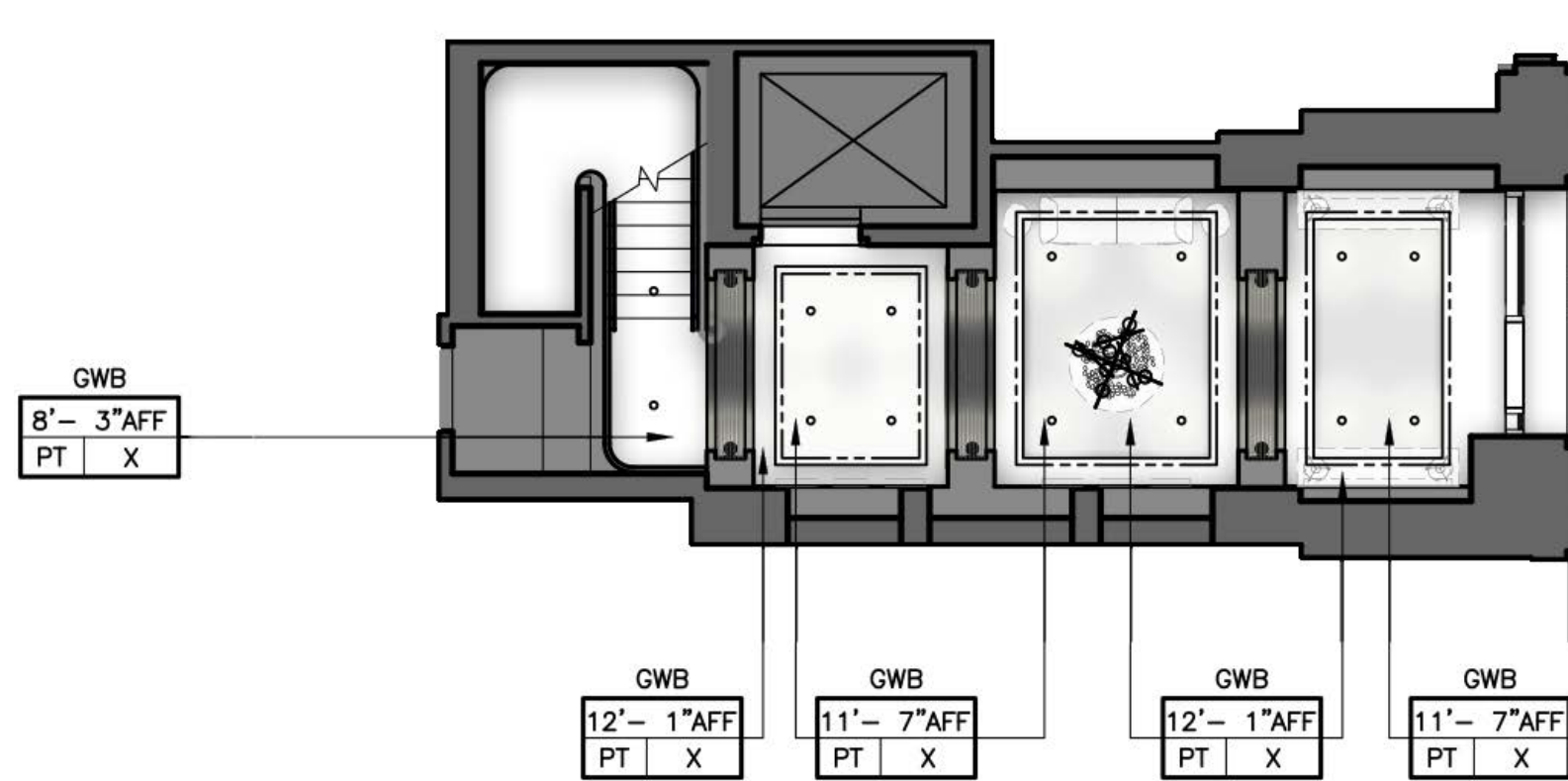

GROUND FLOOR RCP

ELEVATION GROUND FLOOR ARRIVAL FOYER

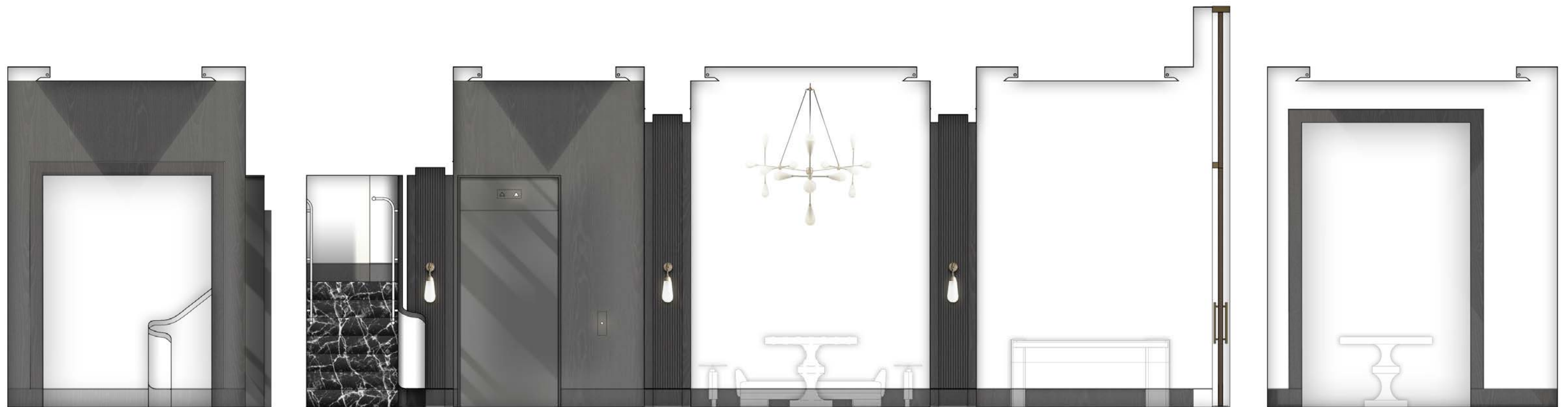
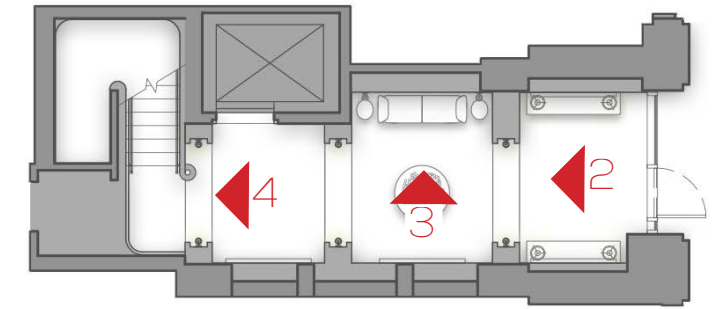

PORTAL TO STAIR

STAIR TO 2ND FLOOR

ELEVATOR LOBBY

FOYER

FOYER ENTRY

PORTAL TO FOYER

4 ELEVATOR LOBBY ELEVATION
N.T.S.

3 FOYER ELEVATION
N.T.S.

2 FOYER PORTAL ELEVATION
N.T.S.

ELEVATION STAIR CASE

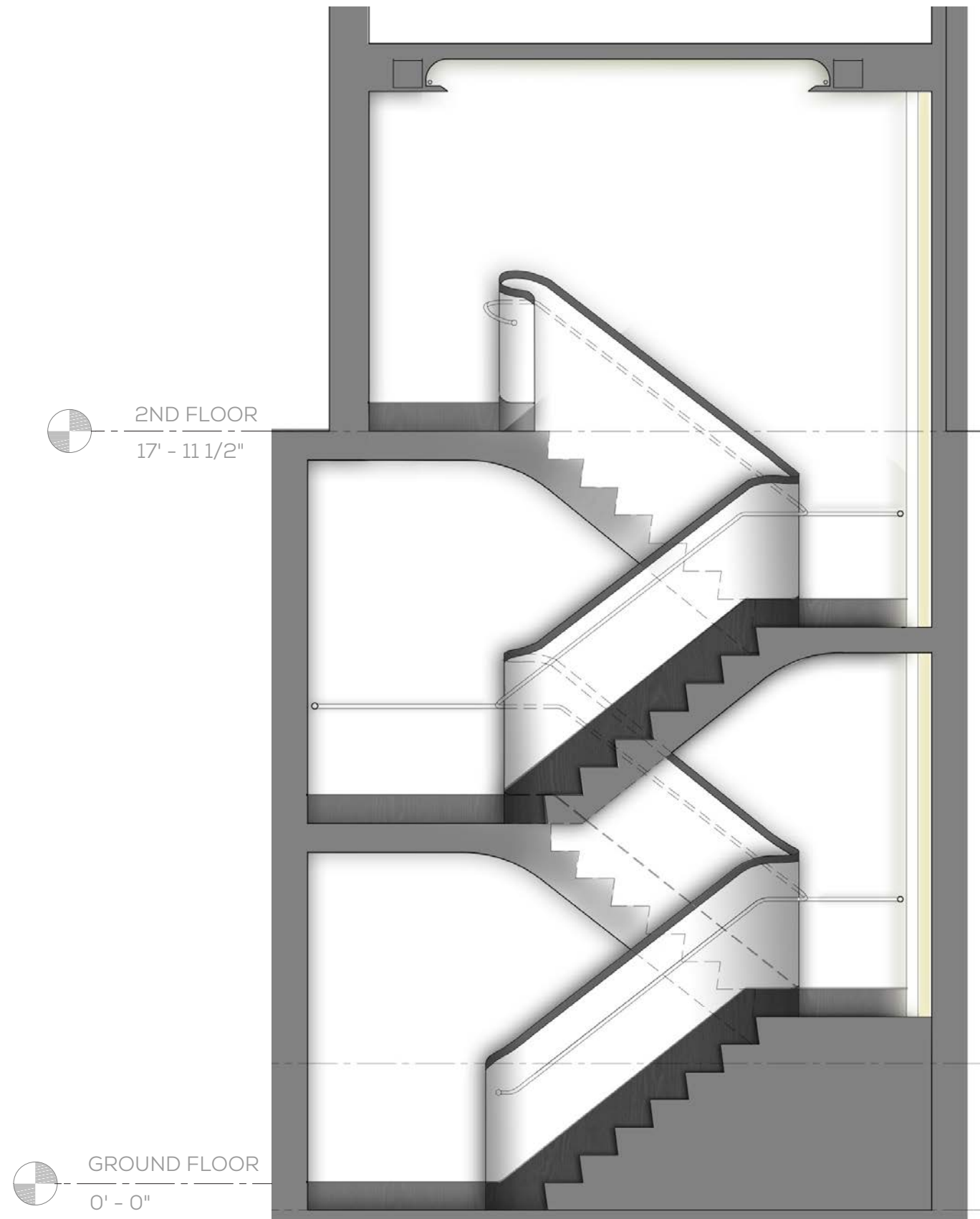

5 STAIR CASE SECTION
N.T.S.

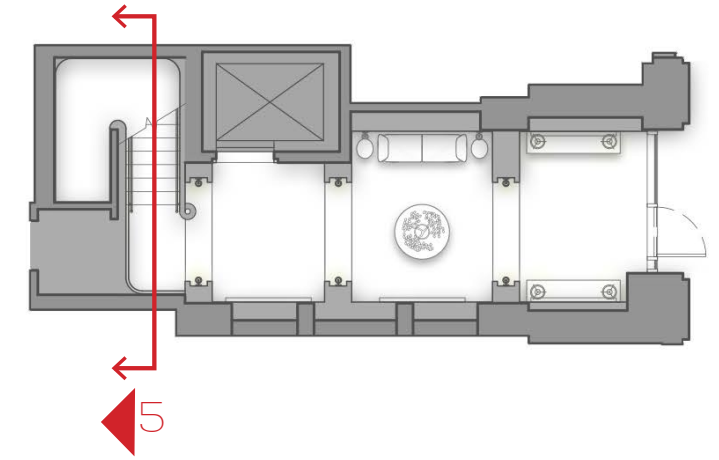

PLANNING 2ND FLOOR PLAN LAYOUT



SECOND FLOOR PLAN

PLANNING 2ND FLOOR REFLECTED CEILING PLAN



03 A SPACE TO GATHER LIVING ROOM



A LIGHT FILLED ROOM

A WARM ATMOSPHERE

RESIDENTIAL ACCENTS

ELEVATION 2ND FLOOR | ARRIVAL

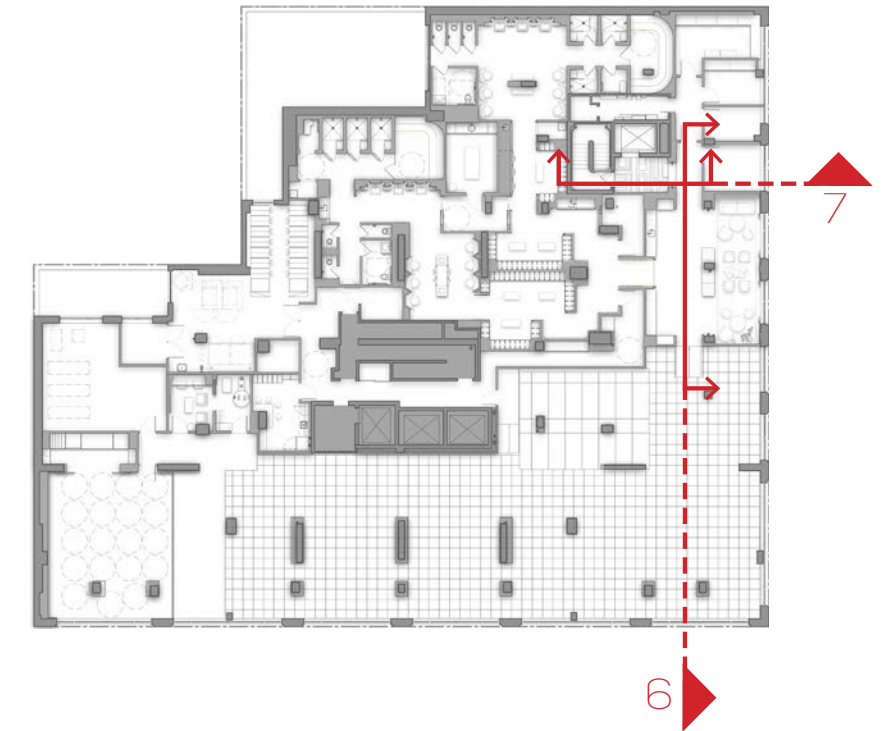

STAIR CASE

ELEVATOR LOBBY

CORRIDOR TO OFFICE

7 2ND FLOOR ARRIVAL FOYER ELEVATION
N.T.S.



TO OFFICE

PORTAL TO LIVING

FIREPLACE

PORTAL TO LIVING

RAMP TO FITNESS

6 2ND FLOOR ARRIVAL FOYER ELEVATION
N.T.S.

02 A SPACE TO NOURISH REFRESHMENT BAR AND RETAIL



WARM WOODS



ECLECTIC FURNISHINGS

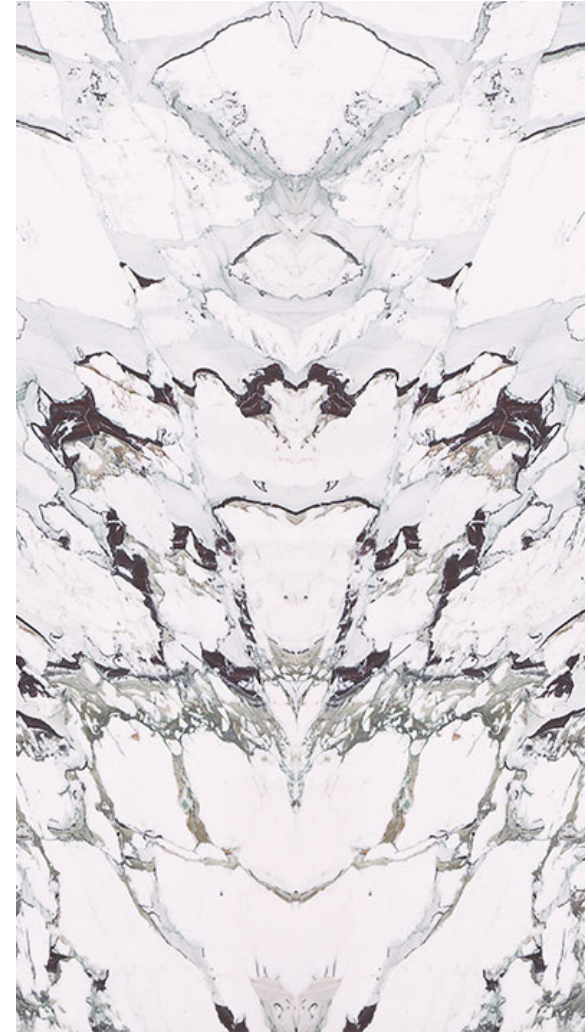

RICH MATERIALITY



ARTFUL TOUCHES

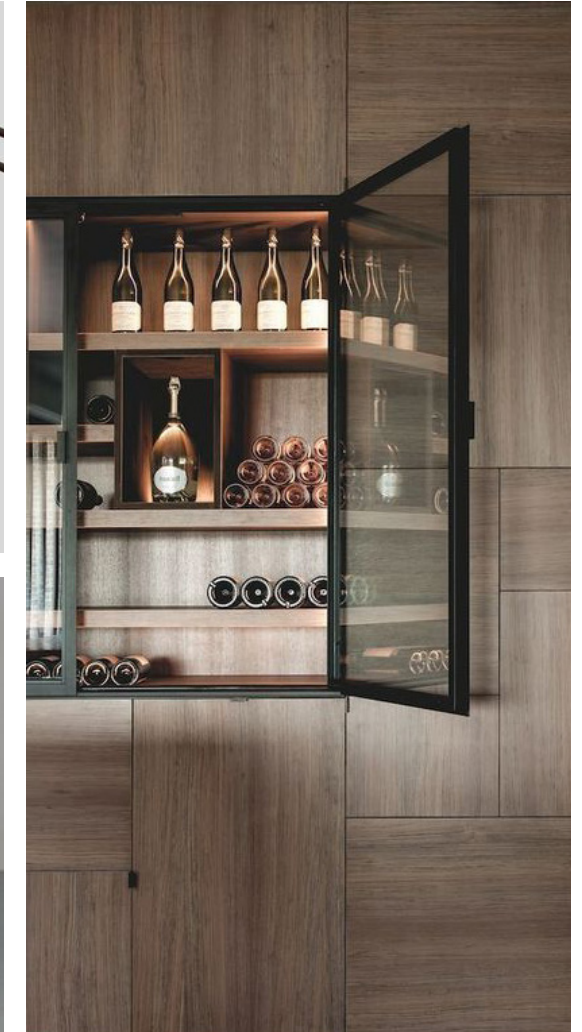

SYMMETRY AND BALANCE

ELEVATION 2ND FLOOR | REFRESHMENT BAR AND RETAIL

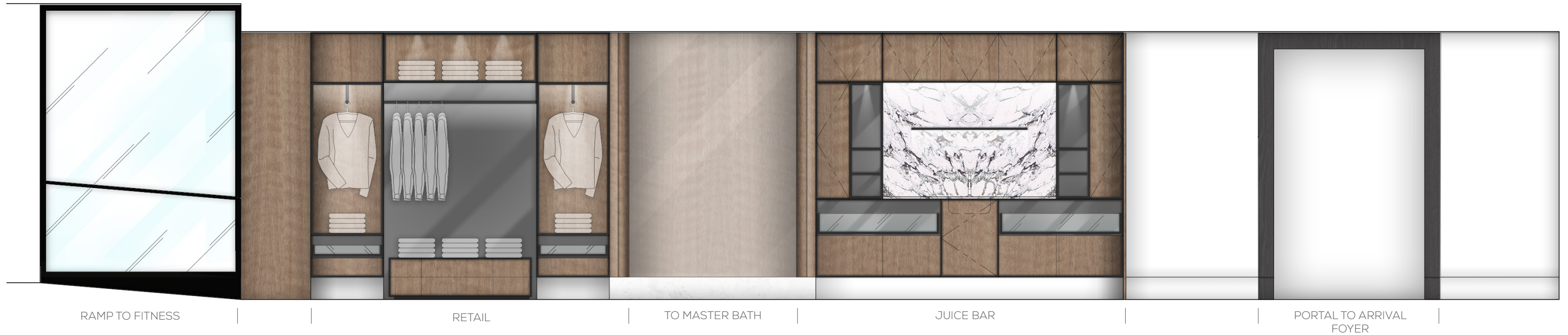
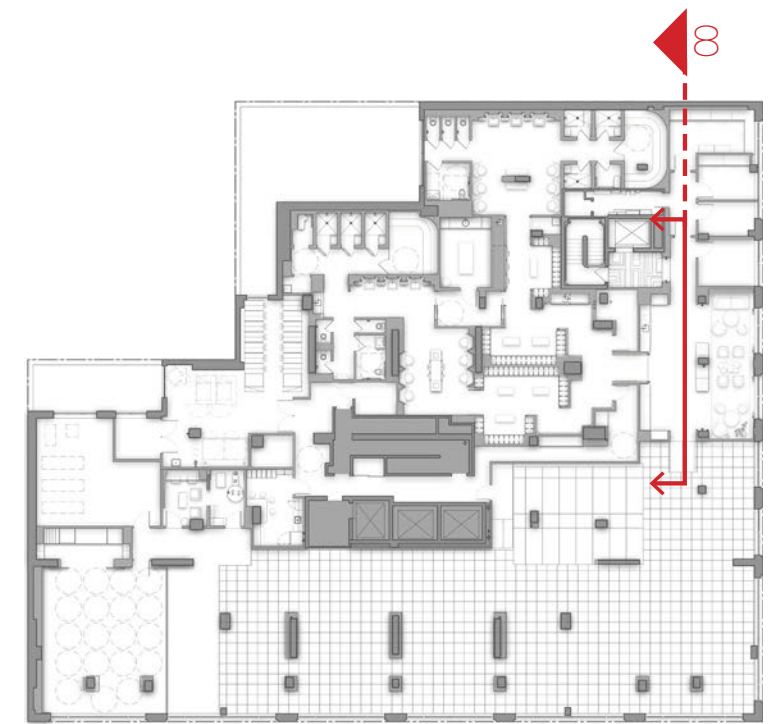

8 2ND FLOOR ARRIVAL FOYER ELEVATION
N.T.S.

ELEVATION 2ND FLOOR | REFRESHMENT BAR



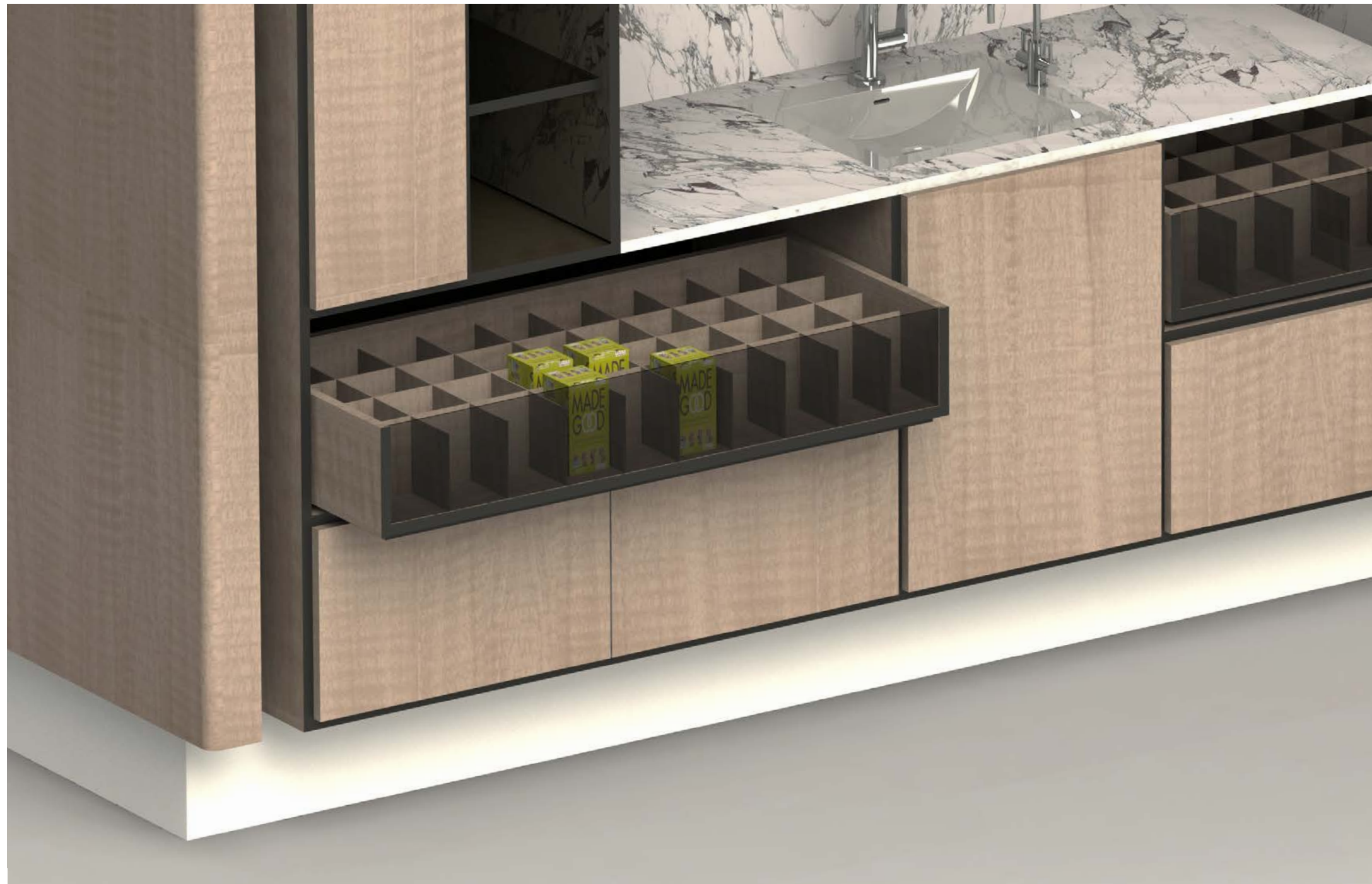

DETAIL FOR SNACK STORAGE DRAWER





DETAIL FOR ACCESSORIES DISPLAY DRAWER

ELEVATION 2ND FLOOR | LIVING

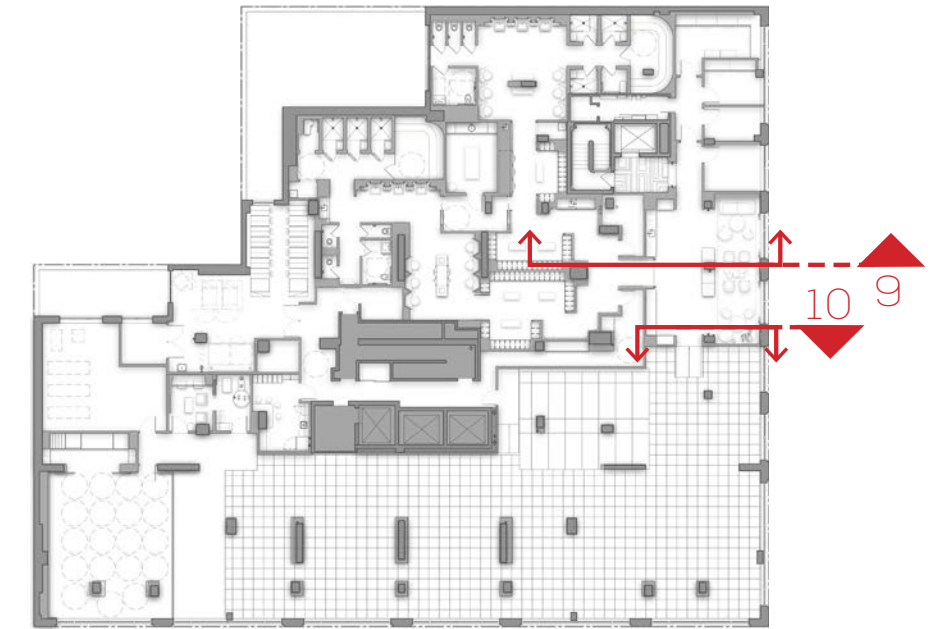

10 2ND FLOOR ARRIVAL FOYER ELEVATION
N.T.S.

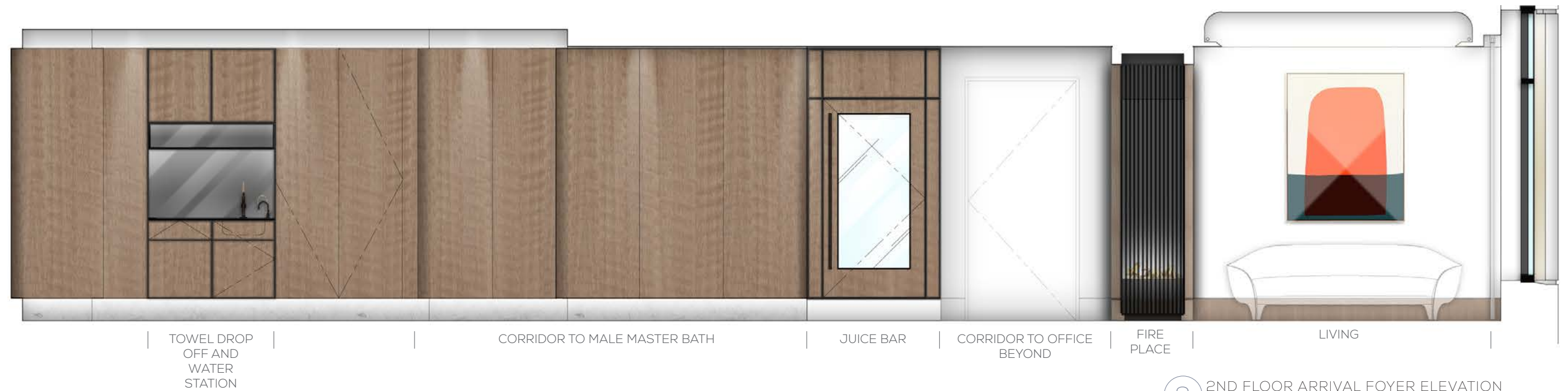

9 2ND FLOOR ARRIVAL FOYER ELEVATION
N.T.S.

04 A PLACE TO CLEANSE MASTER BATH AND SPA



AN UNDERSTATED PALETTE

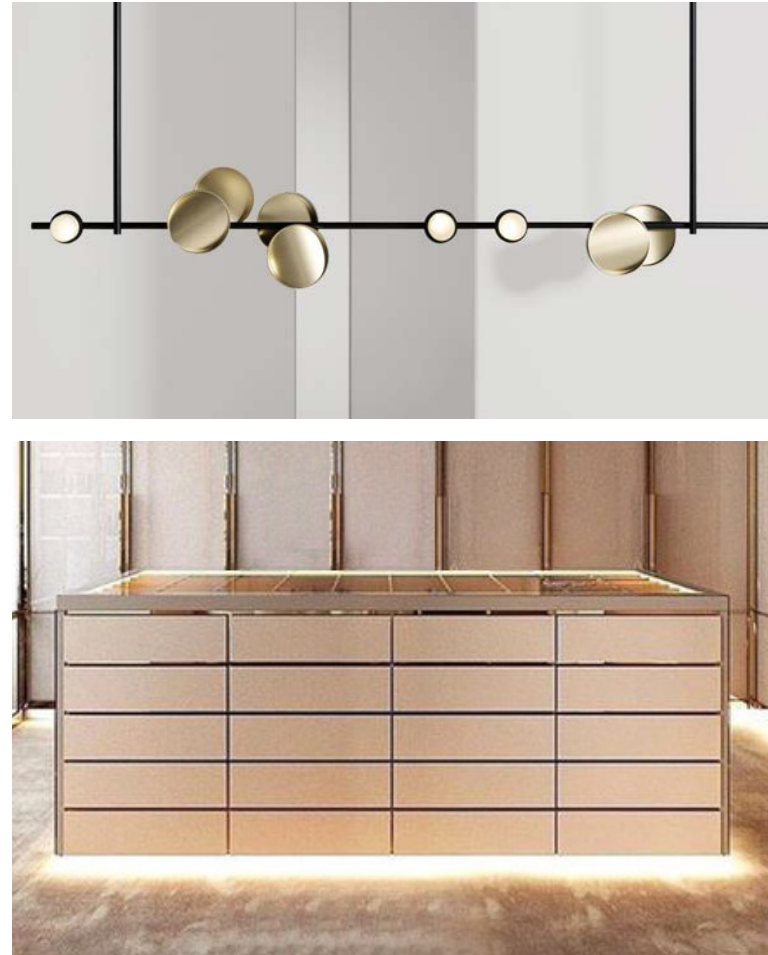

A SPECIAL DRESSING AREA



CONSIDERED DETAILS

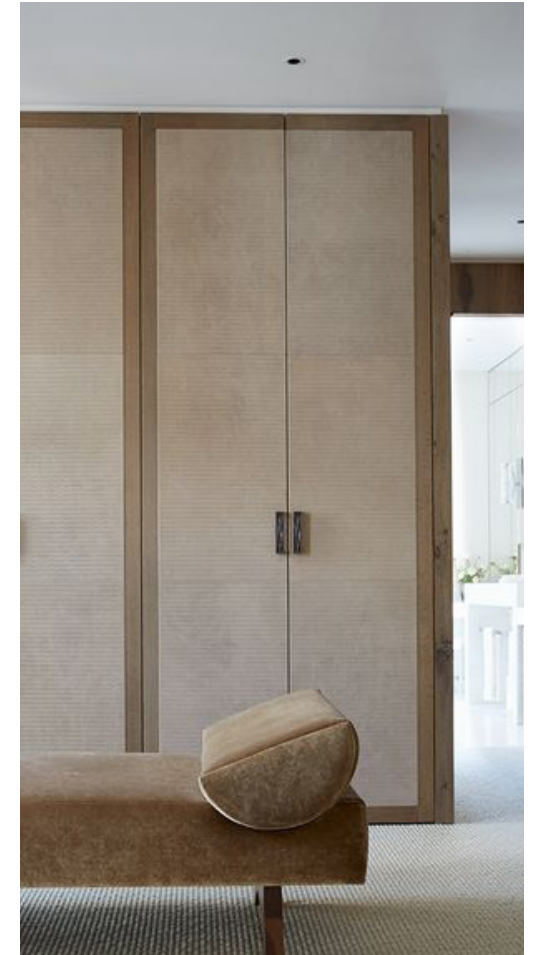

PLANNING MASTER BATH LAYOUT

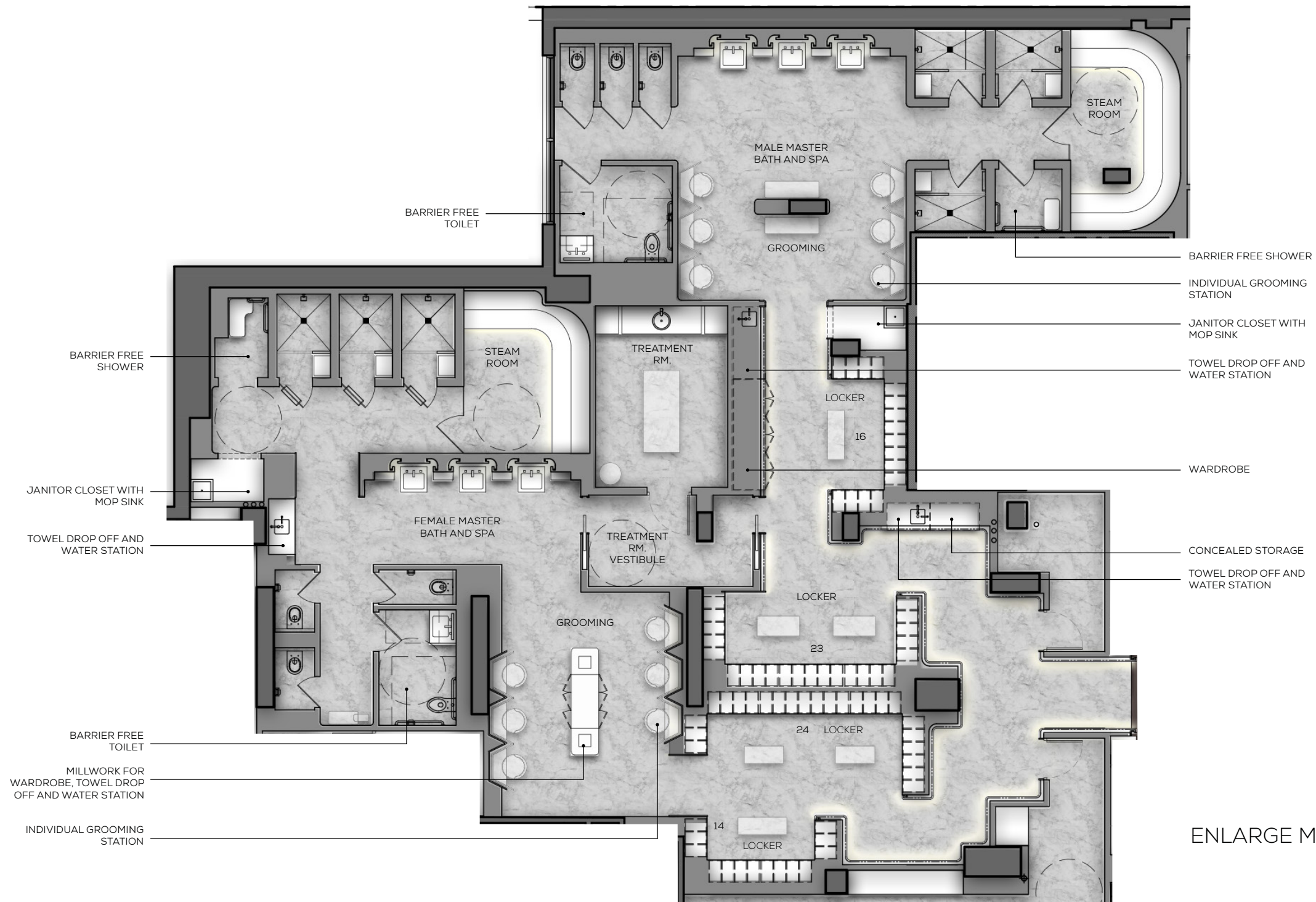

ENLARGE MASTER BATH PLAN LAYOUT

ELEVATION 2ND FLOOR | MASTER BATH TYPICAL LOCKER

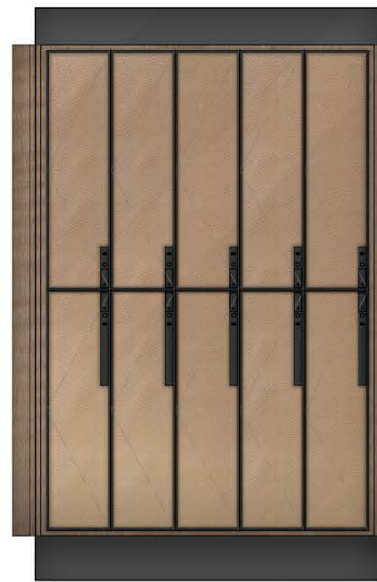
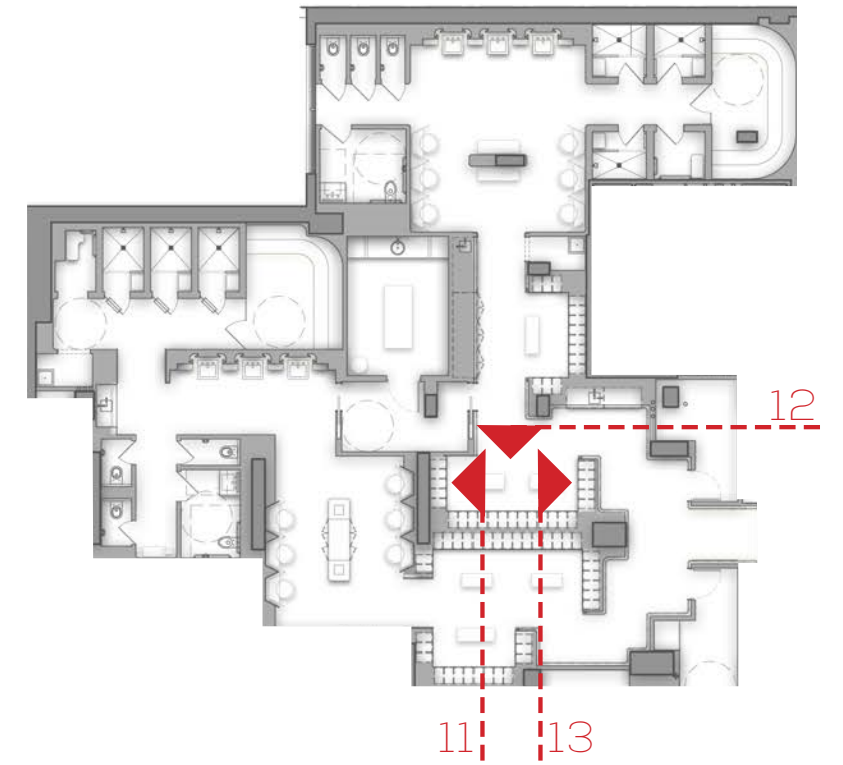

13 LOCKER ELEVATION
N.T.S.

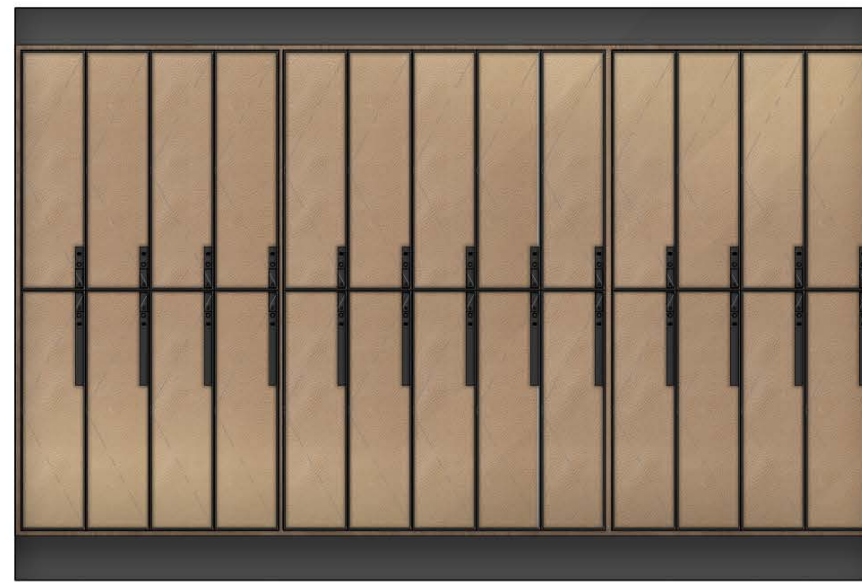

12 LOCKER ELEVATION
N.T.S.



11 LOCKER ELEVATION
N.T.S.

ELEVATION 2ND FLOOR | MASTER BATH TYPICAL LOCKER



ELEVATION 2ND FLOOR | MASTER BATH TYPICAL LOCKER

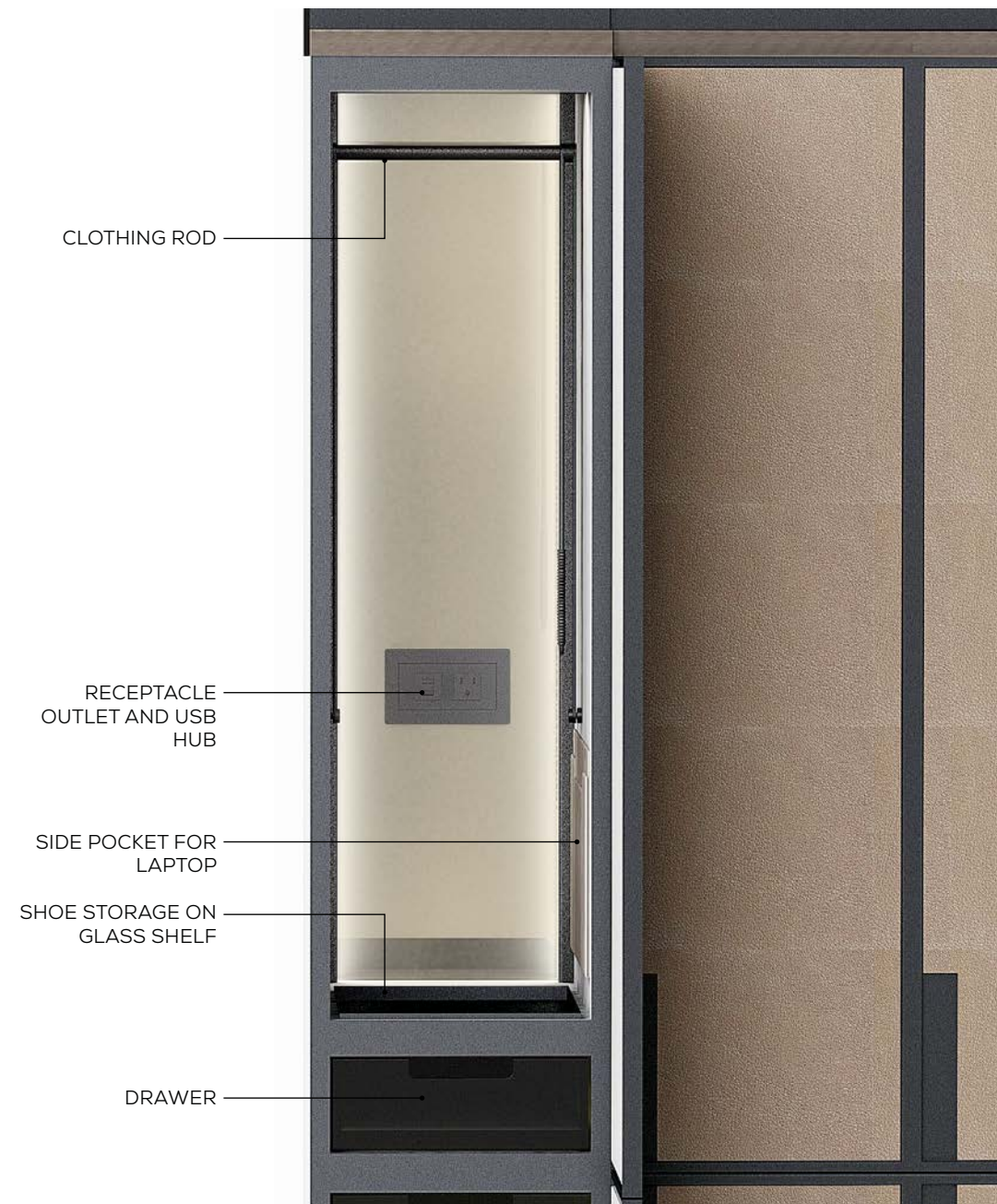

TYPICAL LOCKER FEATURE



TOP AND BOTTOM LOCKER IN OPEN POSITION

ELEVATION 2ND FLOOR | MASTER BATH TYPICAL LOCKER INTERIOR



PULL DOWN CLOTHING ROD FOR TOP TIER LOCKER



DRAWER WITH LEATHER PAD

ELEVATION 2ND FLOOR | MASTER BATH

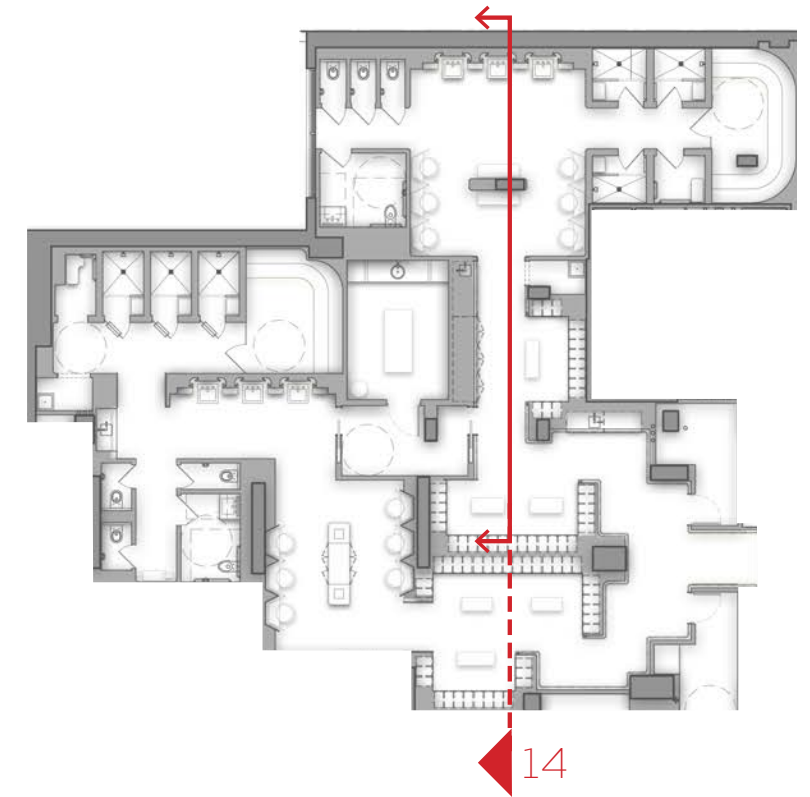

LOCKER

TO TREAT-
MENT ROOM
VESTIBULE

WARDROBE

TOWEL DROP OFF OF
WATER STATION

GROOMING AREA

TO TOILET
STALLS

VANITY

14 MALE MASTER BATH ELEVATION
N.T.S.

ELEVATION 2ND FLOOR | MASTER BATH TYPICAL GROOMING STATION



ELEVATION 2ND FLOOR | MASTER BATH TYPICAL GROOMING STATION



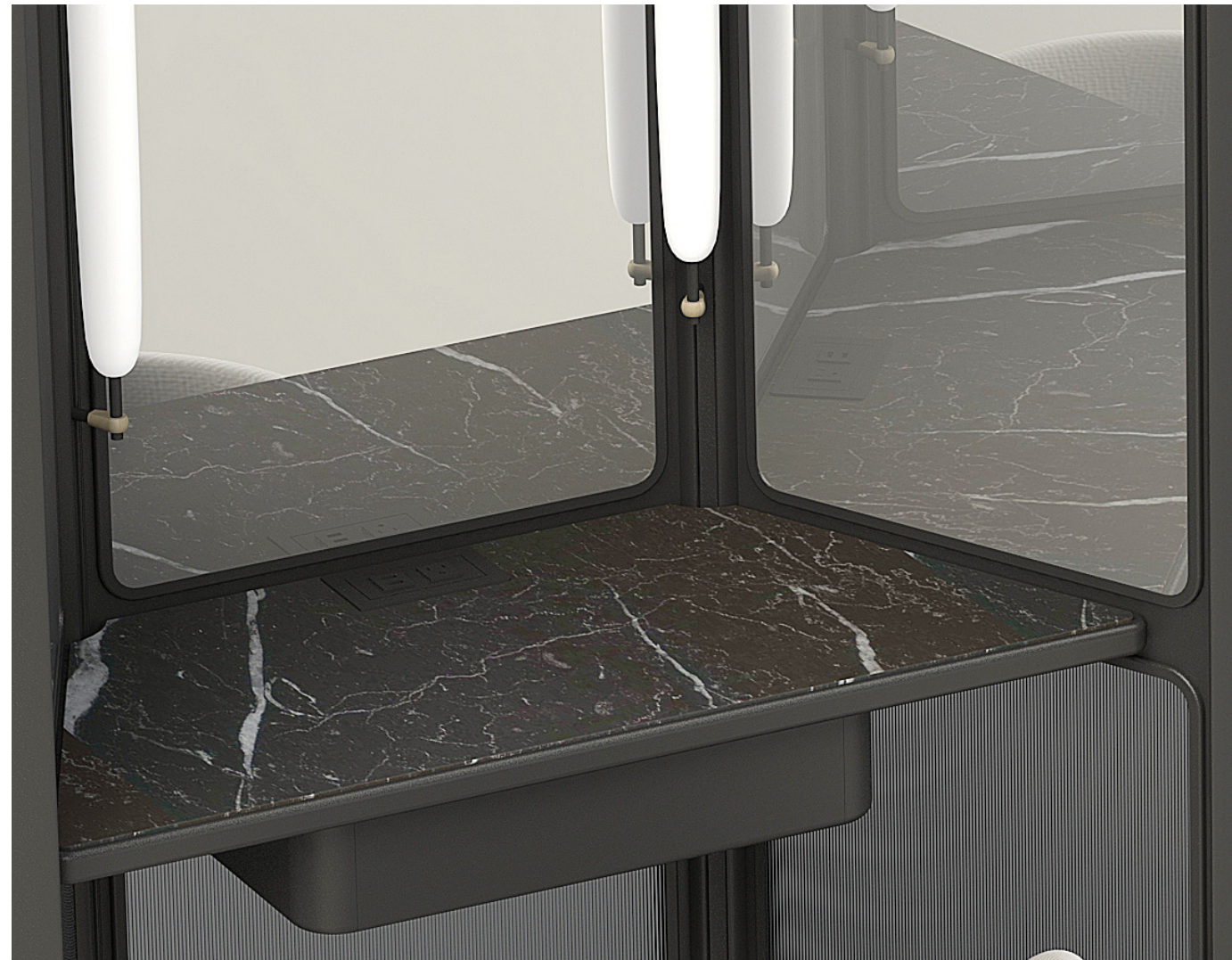

UNDER COUNTER DRAWER FOR HAIR DRYER



GROOMING STATION BASE DETAIL

ELEVATION 2ND FLOOR | MASTER BATH

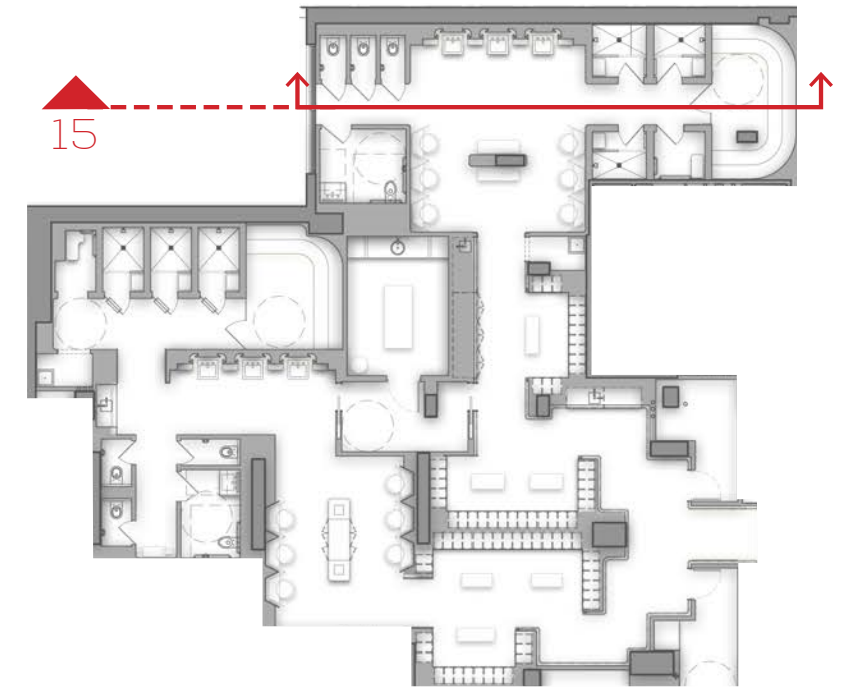

TOILET STALLS

VANITY

TO SHOWER

STEAM ROOM

15 MALE MASTER BATH ELEVATION
N.T.S.

ELEVATION 2ND FLOOR | MASTER BATH VANITY



ELEVATION 2ND FLOOR | MASTER BATH VANITY



ELEVATION 2ND FLOOR | MASTER BATH TYPICAL TOILET STALL



18 TOILET STALL ELEVATION
N.T.S.



17 TOILET STALL ELEVATION
N.T.S.

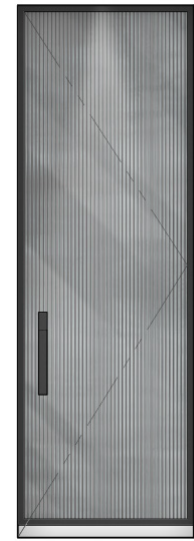

16 TOILET STALL DOOR ELEVATION
N.T.S.

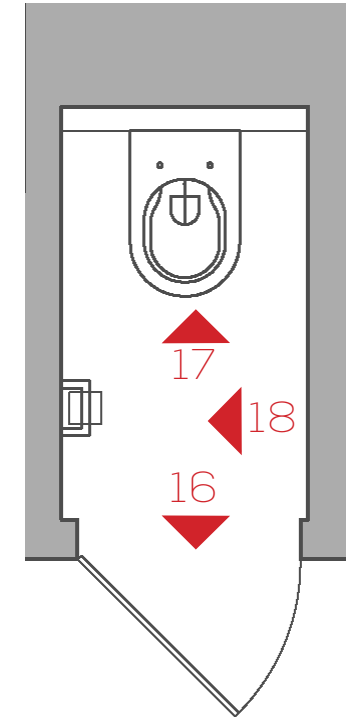

PLUMBING FIXTURE BY FANTINI - MILANO COLLECTION

ELEVATION 2ND FLOOR | MASTER BATH TYPICAL SHOWER STALL



21 SHOWER STALL ELEVATION
N.T.S.



20 SHOWER STALL ELEVATION
N.T.S.

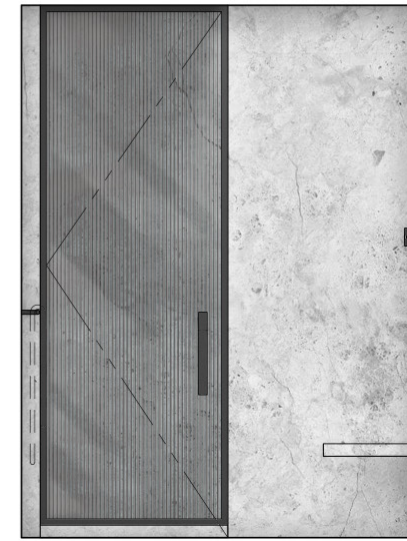

19 SHOWER STALL DOOR ELEVATION
N.T.S.

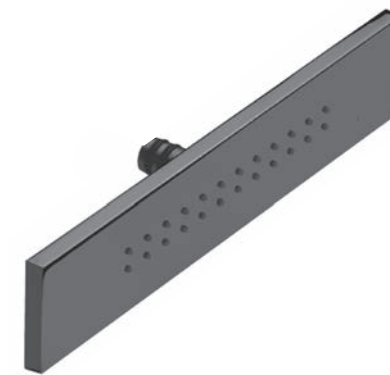
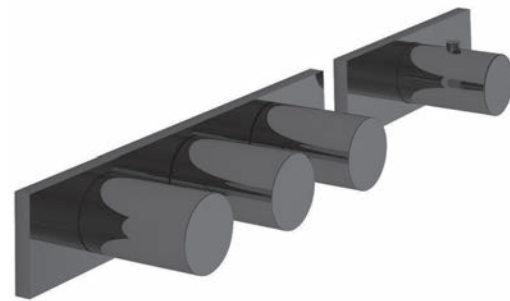
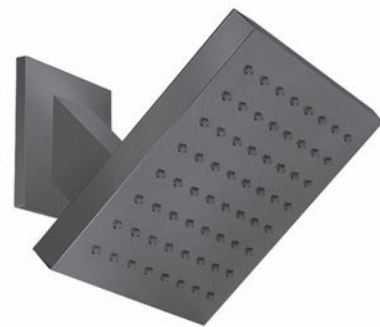
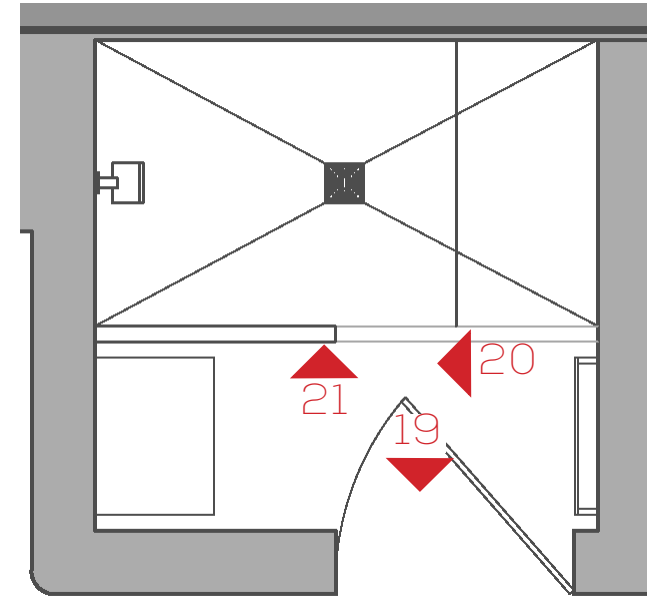

PLUMBING FIXTURE BY FANTINI - MILANO COLLECTION

05 A SPACE FOR TRANSFORMATION PERSONAL FITNESS STUDIO

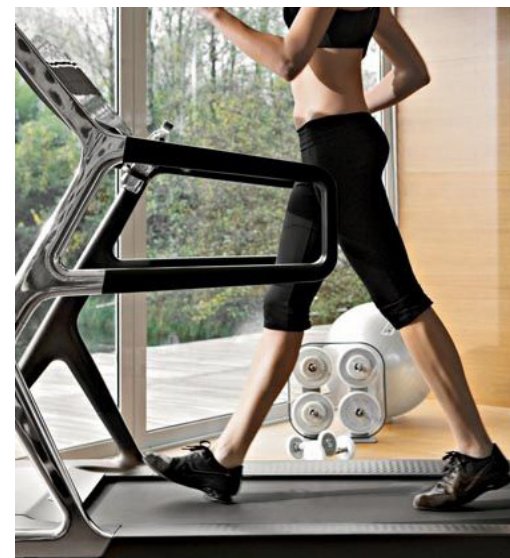

ILLUMINATED AND INSPIRING

MOMENTS OF LUXURY

STRENGTH & FUNCTION

ELEVATION 2ND FLOOR | FITNESS AREA



23 TYPICAL MIRROR COLUMN ELEVATION
N.T.S.

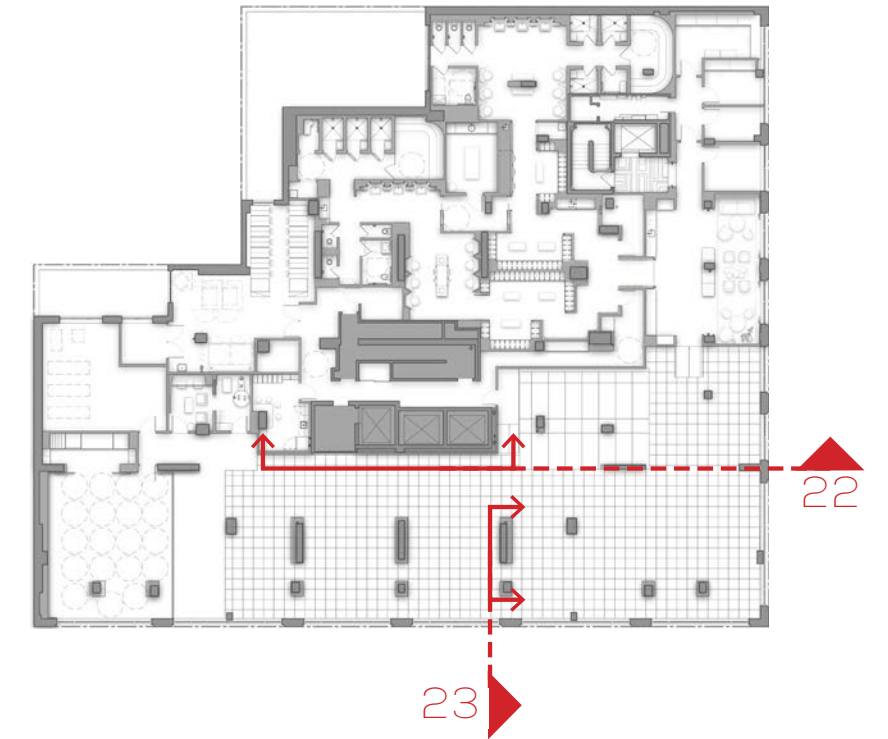

22 TYPICAL MIRROR WALL ELEVATION
N.T.S.



THANK YOU

