

BRIDGEWATER MARRIOTT

SUITE MOCK UP FF&E- NOVEMBER 1, 2017

AUTOGRAPH
COLLECTION®
HOTELS

PEARLE
HOSPITALITY

STUDIO
MUNGE

WE DO MORE THAN INTERIOR DESIGN.

We think beyond walls and floors and imagine the shared experience.

WE CREATE MORE THAN PRETTY PICTURES.

Studio Munge creates the energy that audiences respond to and brings businesses to life.

Since 1997, we have been positively impacting the communities and cities we design in.

WE IMAGINE EXCITING SPACES.

Spaces that people want to be a part of. We have a keen insight, foresight, and passion for the flow of design that brings a space to life.

MODERN COTTAGE



PLACE OF RETREAT



MODERN LAKE HOUSE

The family spent their first day in this remote lake house, set in a tangle of trees formed with astonishment, grassed with familiarity, flowering with impressions, and begging for touch and discovery, and what sounds could be drawn were faint, forgotten melodies echoing down the hallways and through the chambers, Looking out the windows as the season changes....

Michelle Dane



CONNECTED TO NATURE

MEMORIES ARE CREATED



A JOURNEY EMBRACING EACH SEASON

WINTER WARMTH

SPRING AWAKENING

SUMMER VITALITY

AUTUMN COLOURS

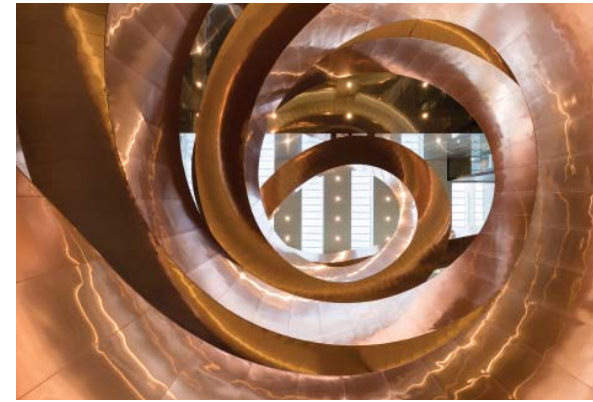

BRIDGEWATER HOTEL

Burlington is a city that embraces the unique character of its relax lake living. Bridgewater Hotel, located where the lake meets the shores. The surrounding, Spencer park and the Brant Pier, frame a perfect gateway offering its guests a truly distinct, personal and local experience in every season.

OVERALL FEEL: TIMELESS

Filled with daylight and views to outdoors, we see bridgewater hotel as an unexpected retreat within the city. A property marrying an appreciation for the great outdoors nestled within contemporary setting set in growing cosmopolitan city.

HONEST

NATURAL

ELEGANT

TIMELESS

WARM

FRESH

CONTEMPORARY

SUMMER:

Song of Summer

Move the shoulders,
shake the arms!

And the noon wind
breathes in the face

-July, TCHAIKOVSKY

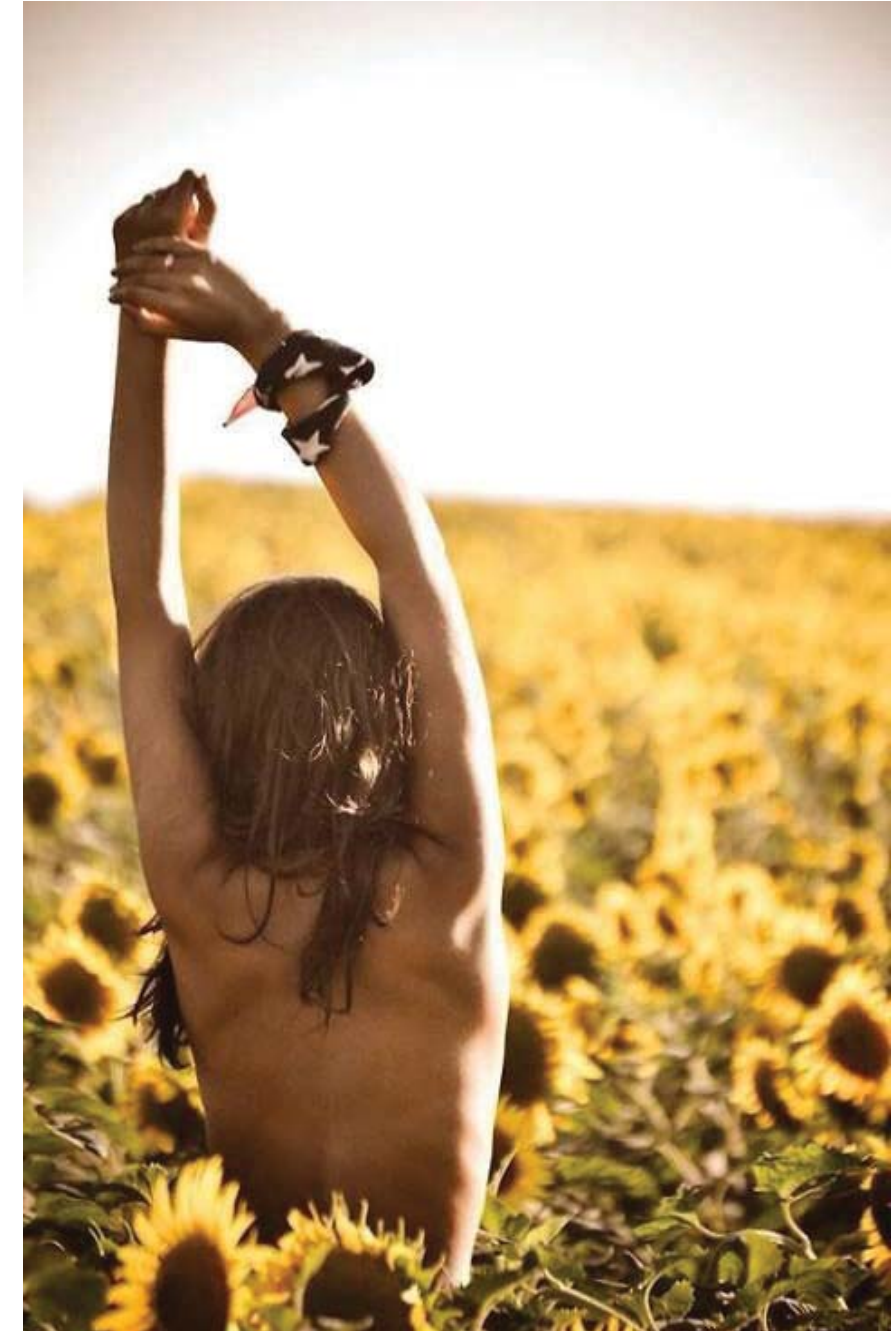

SUITE CORRIDOR CONCEPT IMAGES

DIRECTION



MODERN LINES



REVEAL EXPRESSED WITH LIGHTS

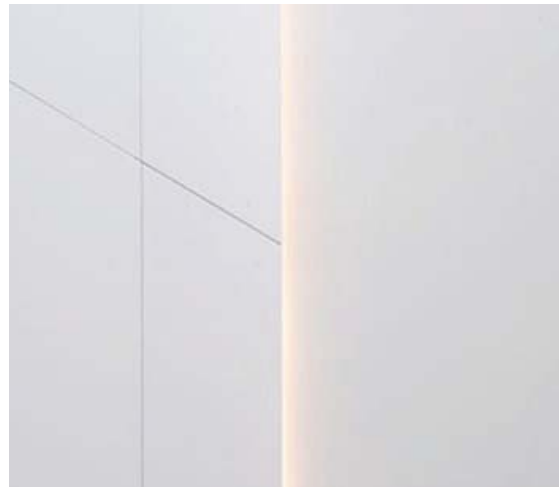

WARMTH IN MATERIALS



TASTEFUL FORMS



SENSES

CHANGE IS COLOUR

SUITE CONCEPT IMAGES

DETAIL



SENSUAL



PLAYFUL



CONNECTED TO NATURE



SOFT



MODERN & WARM

SUITE BATHROOM CONCEPT IMAGES



SUITES MATERIAL PALETTE



- 1 DRAPERY
- 2 SHEER
- 3 WOOD AT FLOOR AND WALLS
- 4 TYP. NICKEL PLUMBING FIXTURES
- 5 STONE AT BATHROOM WALLS
- 6 TILE AT BATHROOM FLOOR
- 7 WOOD AT CLOSET AND DESK
- 8 WALLCOVERING
- 9 CHAISE FABRIC
- 10 CHAISE ACCENT FABRIC
- 11 HEADBOARD & BEDFRAME LEATHER
- 12 AREA RUG COLOUR POMS
- 13 DESK & SIDE TABLE STONE
- 14 TYP. FF&E DISTRESSED METAL
- 15 TYP. FF&E WOOD
- 16 DESK CHAIR LEATHER
- 17 DESK CHAIR WOOD
- 18 OUTDOOR SOFA ACCENT FABRIC
- 19 OUTDOOR SOFA FABRIC
- 20 OUTDOOR LOUNGE CHAIR ACCENT FABRIC
- 21 OUTDOOR LOUNGE CHAIR FABRIC
- 22 OUTDOOR FURNITURE METAL
- 23 OUTDOOR SOFA BACK FABRIC BANDS
- 24 OUTDOOR LOUNGE CHAIR BACK ROPE

SUITE LAYOUTS 3RD FLOOR

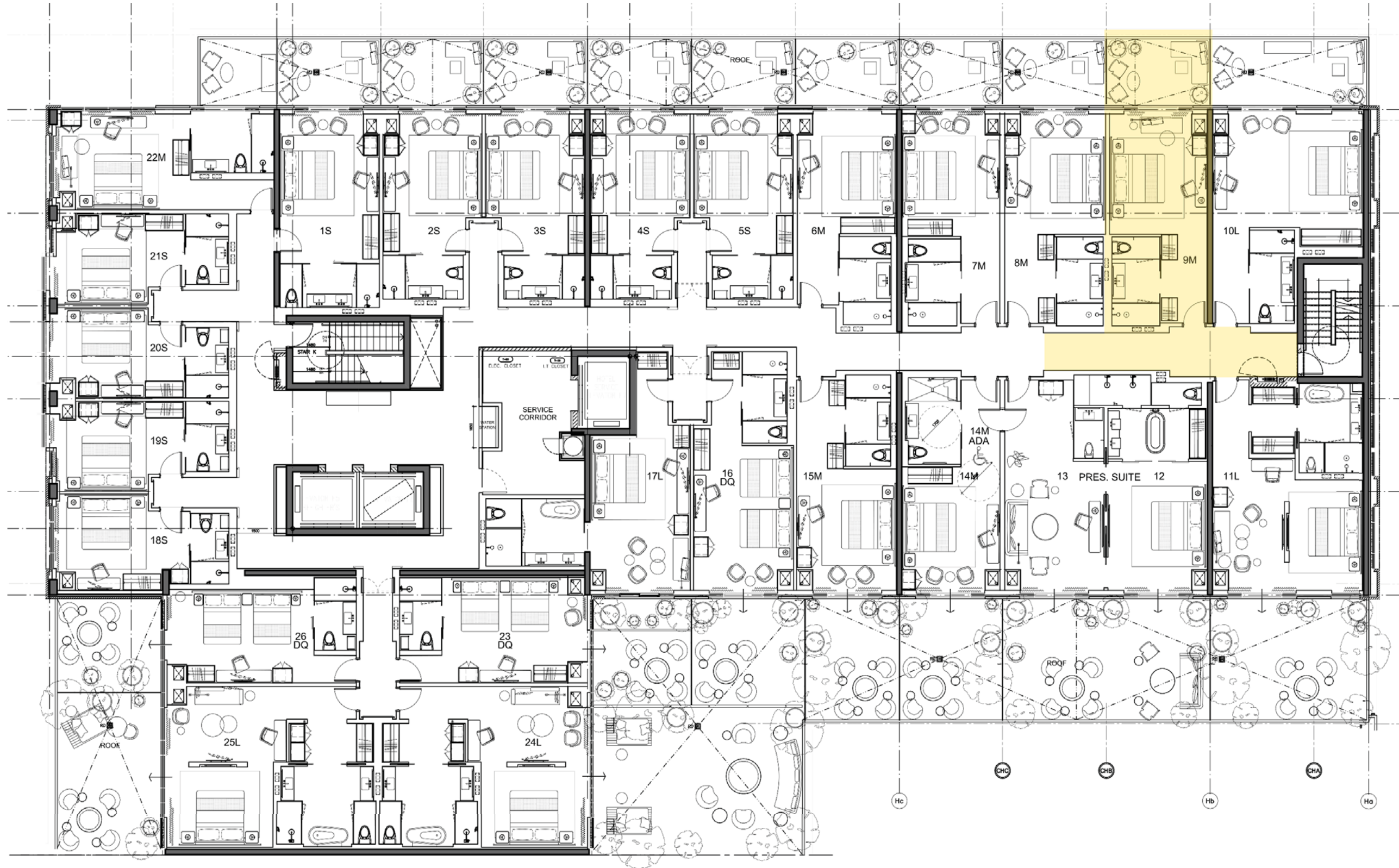

SUITE LAYOUT 9M-3RD FLOOR CORRIDOR

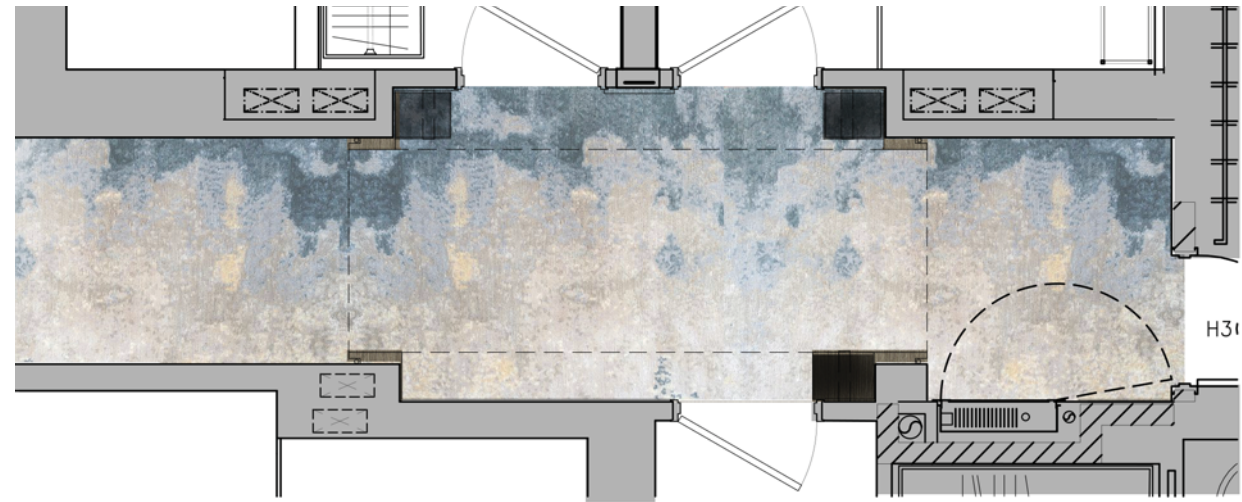

CORRIDOR FLOOR FINISHES PLAN

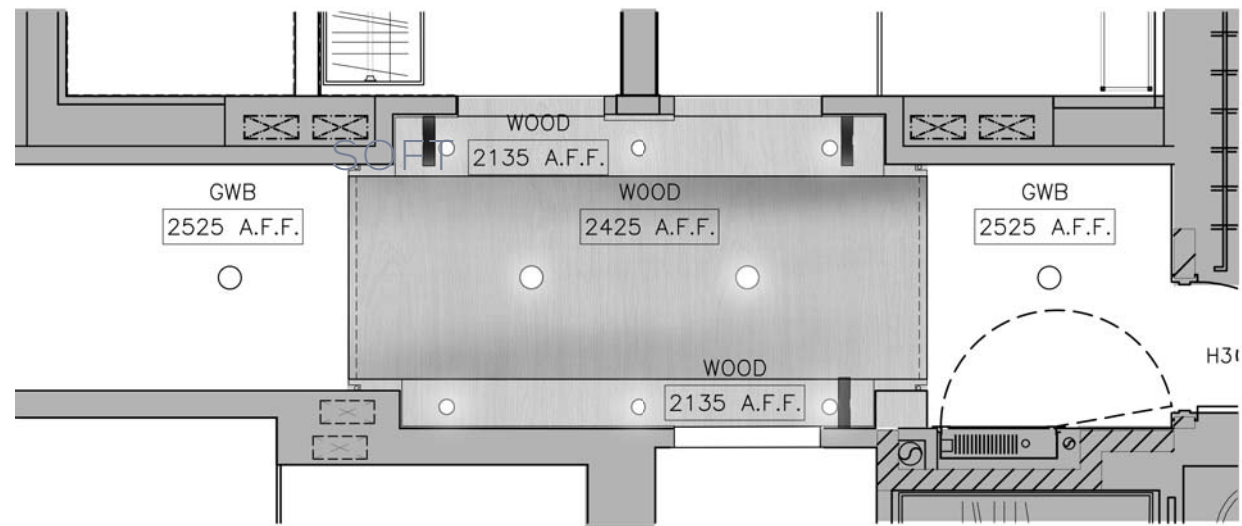

CORRIDOR REFLECTIVE CEILING PLAN

SUITE LAYOUT 9M SUITE ENTRANCE -3RD FLOOR

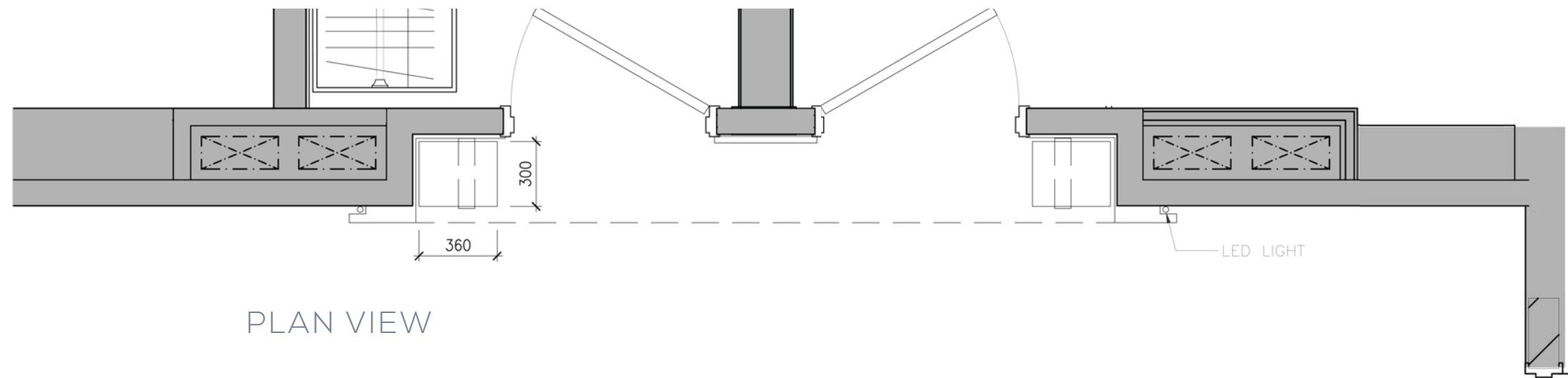

PLAN VIEW



FRONT ELEVATION

SUITE LAYOUT 9M SUITE ENTRANCE -3RD FLOOR

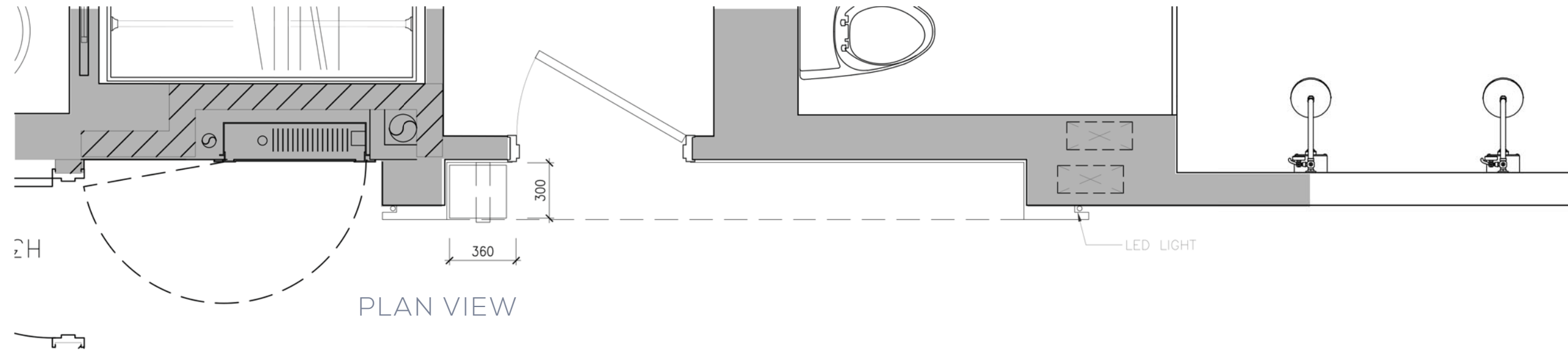

SUITE LAYOUT 9M SUITE ENTRANCE -3RD FLOOR



SUITE LAYOUT 9M SUITE ENTRANCE -3RD FLOOR



SUITE LAYOUT 9M-3RD FLOOR PLANS

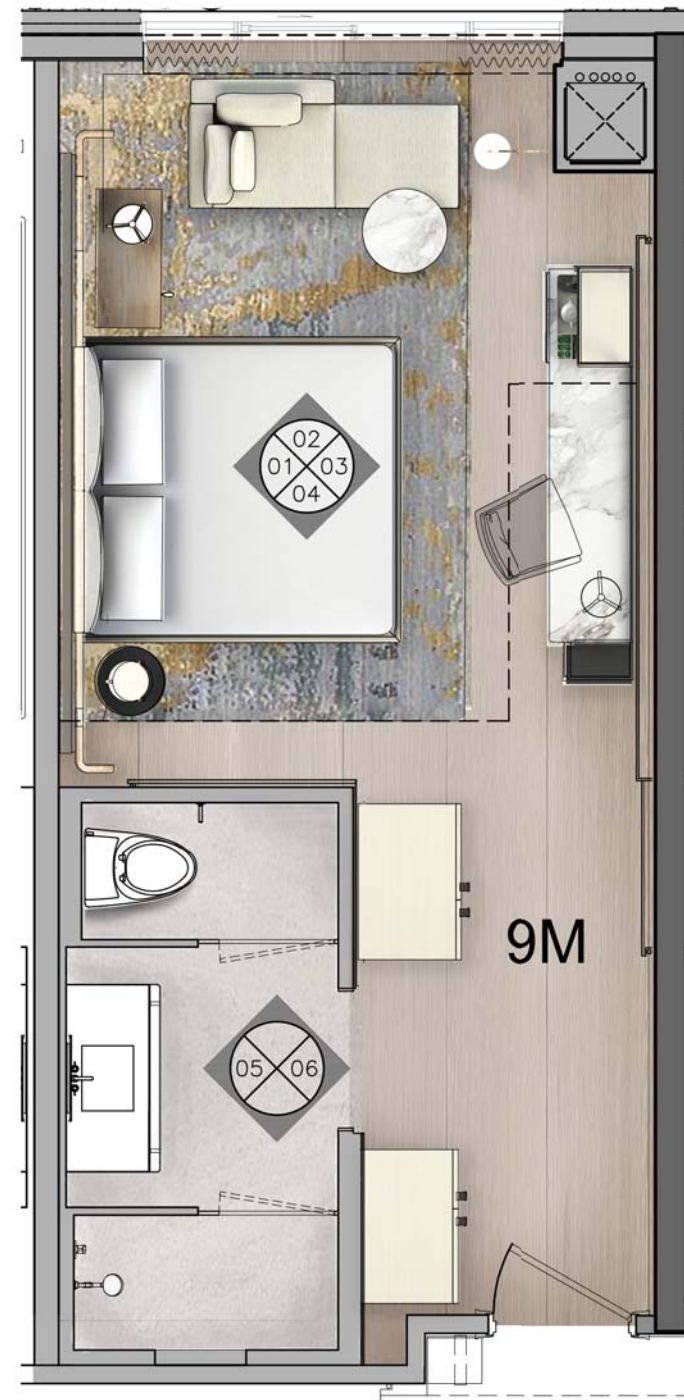

FURNITURE PLAN

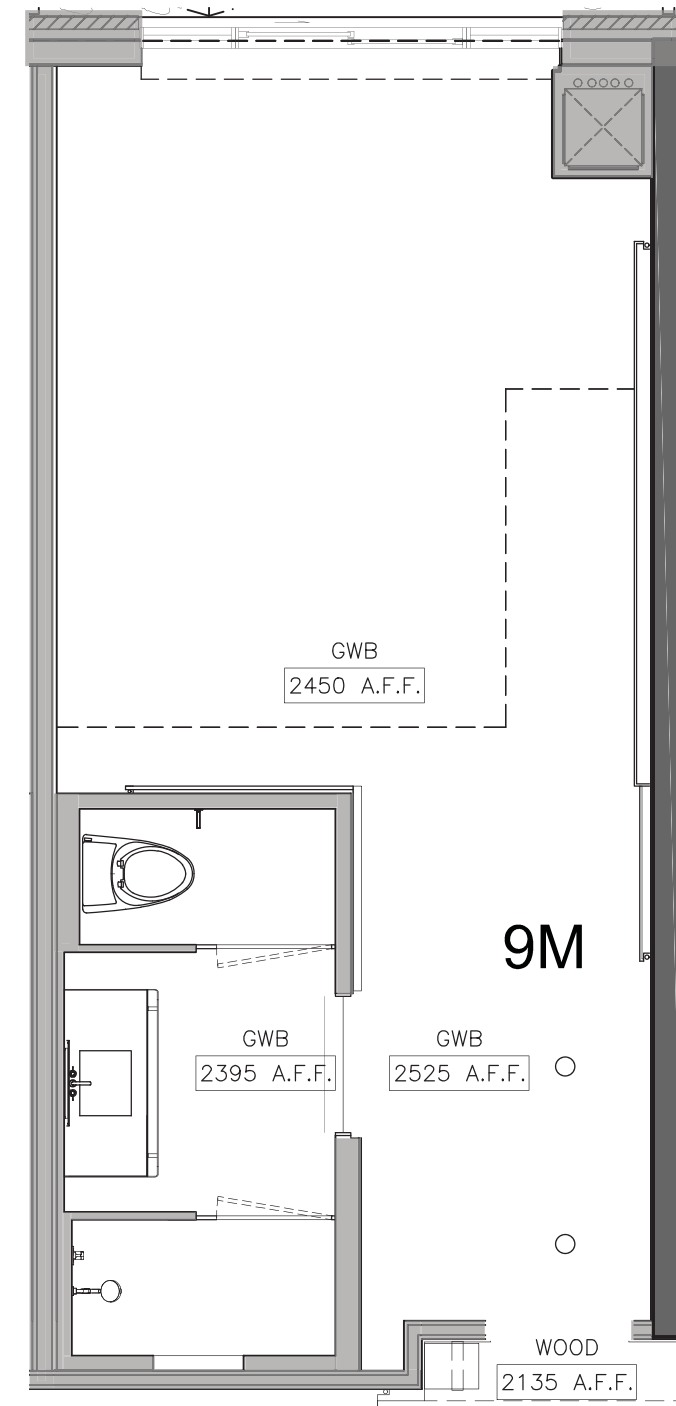

REFLECTIVE CEILING PLAN

SUITE LAYOUTS 9M-3RD FLOOR ELEVATIONS

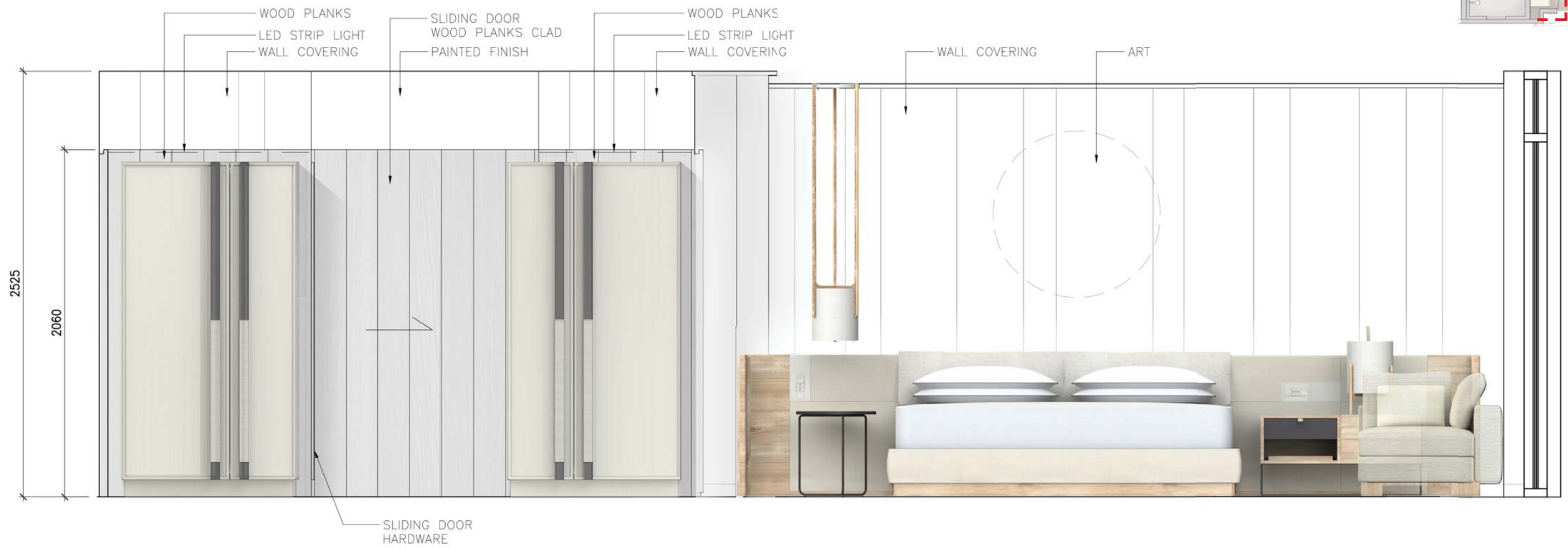
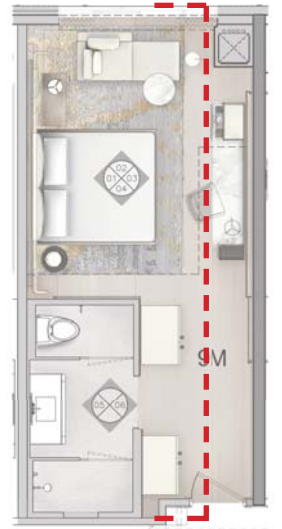

ELEVATION 1



ELEVATION 2

SUITE LAYOUTS 9M-3RD FLOOR ELEVATIONS

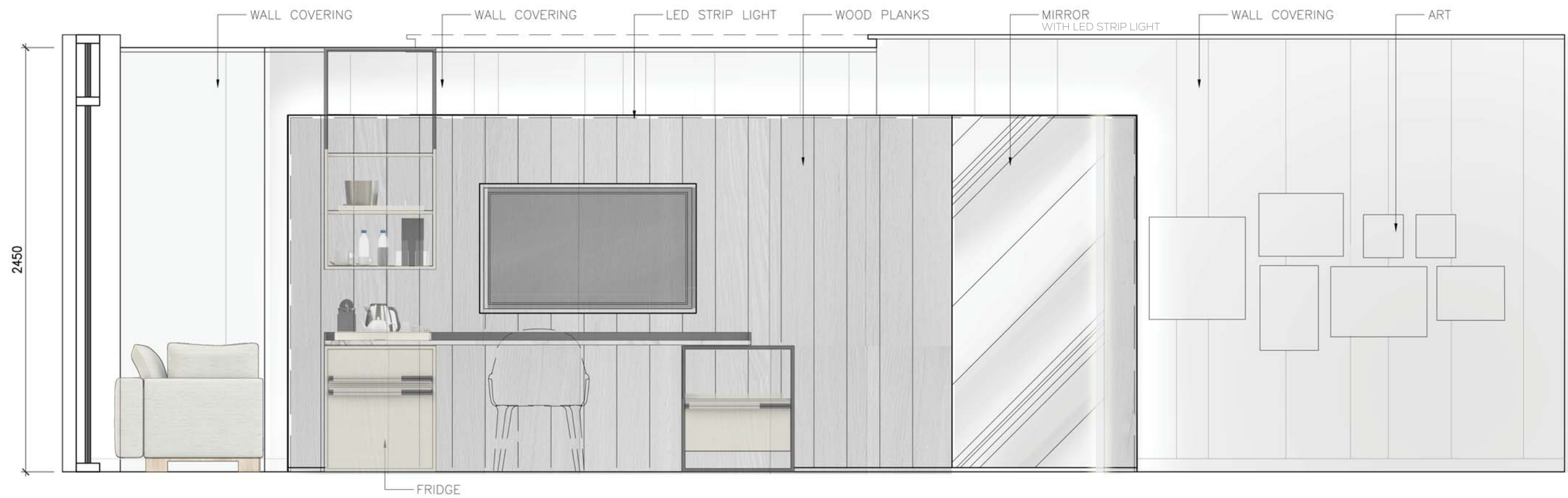
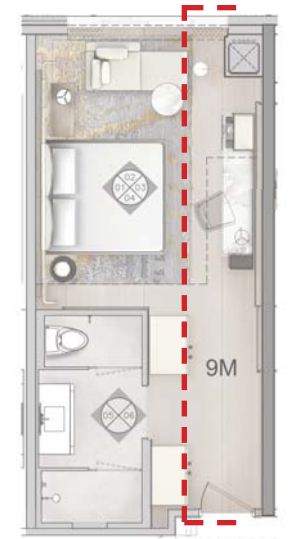

ELEVATION 3

SUITE LAYOUTS 9M-3RD FLOOR ELEVATIONS



ELEVATION 4

SUITE LAYOUTS 9M-3RD FLOOR PERSPECTIVES

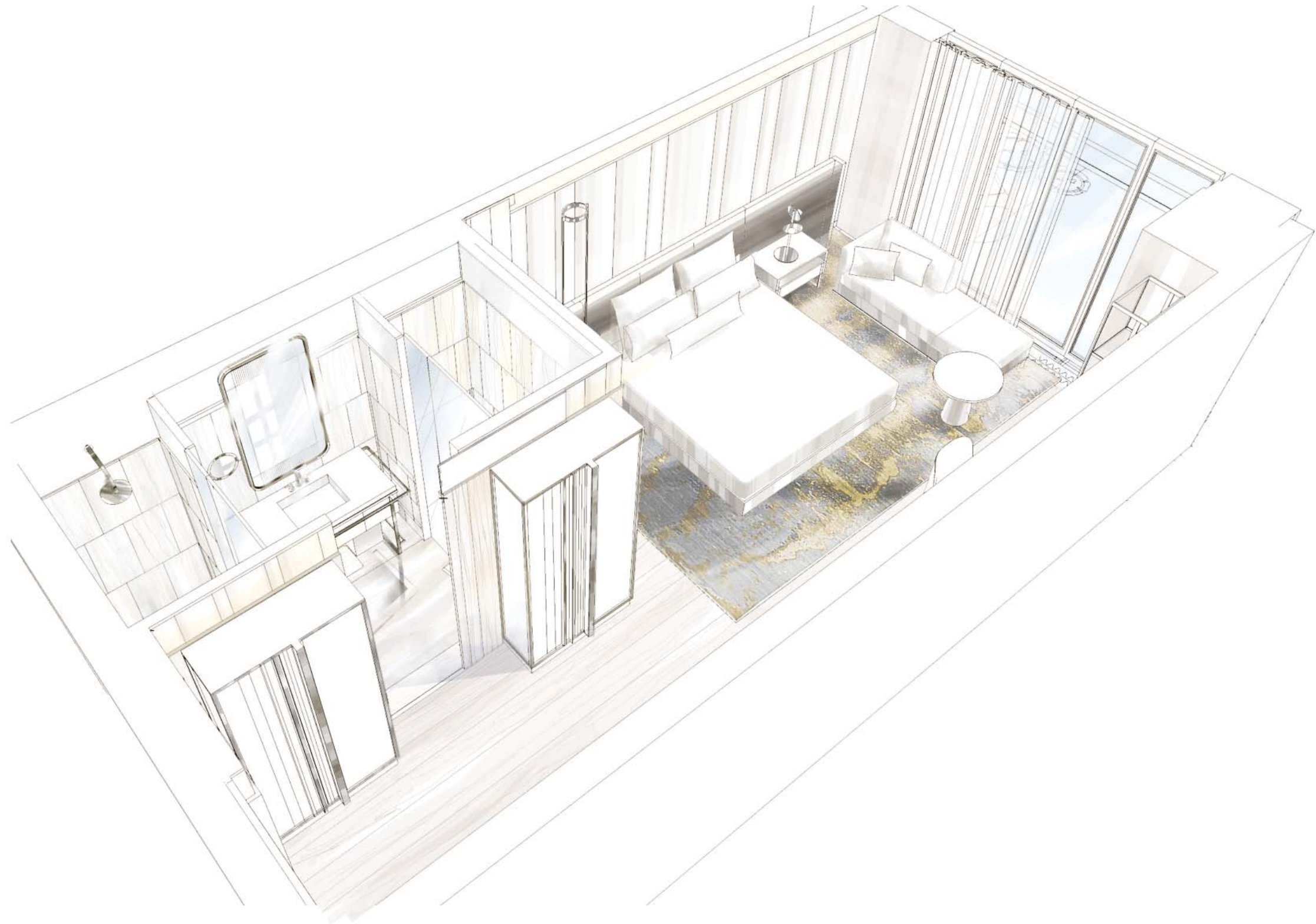

SUITE LAYOUTS 9M-3RD FLOOR PERSPECTIVES



SUITE LAYOUTS 9M-3RD FLOOR PERSPECTIVES

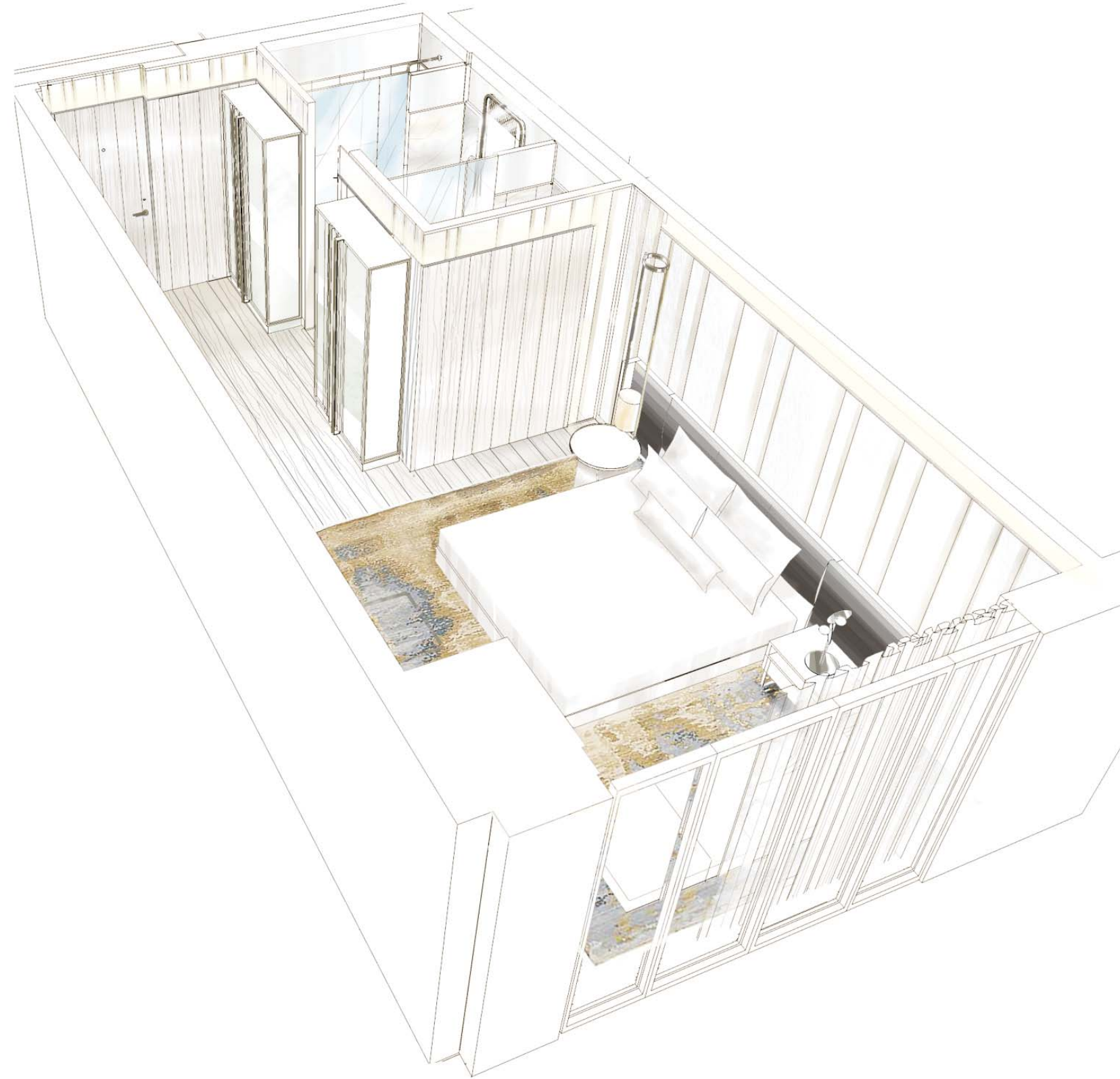

SUITE LAYOUTS 9M-3RD FLOOR PERSPECTIVES



SUITE LAYOUTS 9M-3RD FLOOR PERSPECTIVES



SUITE LAYOUTS 9M-3RD FLOOR - FURNITURE CONCEPT



MATERIAL SWATCHES



TYPICAL WOOD



FABRIC AND LEATHER FOR HEADBOARD AND BEDFRAME. LEATHER ON DRAWER FRONT.



TYPICAL DISTRESSED BLACK METAL

HEADBOARD, BED AND NIGHTSTAND DESIGNS



SUITE LAYOUTS 9M-3RD FLOOR - FURNITURE CONCEPT

MATERIAL SWATCHES



UPHOLSTERY AND TOSS CUSHION FABRICS



STONE



TYPICAL WOOD



CUSTOM CHAISE UPHOLSTERED IN FABRIC WITH WOOD BASE.

CUSTOM TABLE WITH STONE TOP AND WOOD BASE

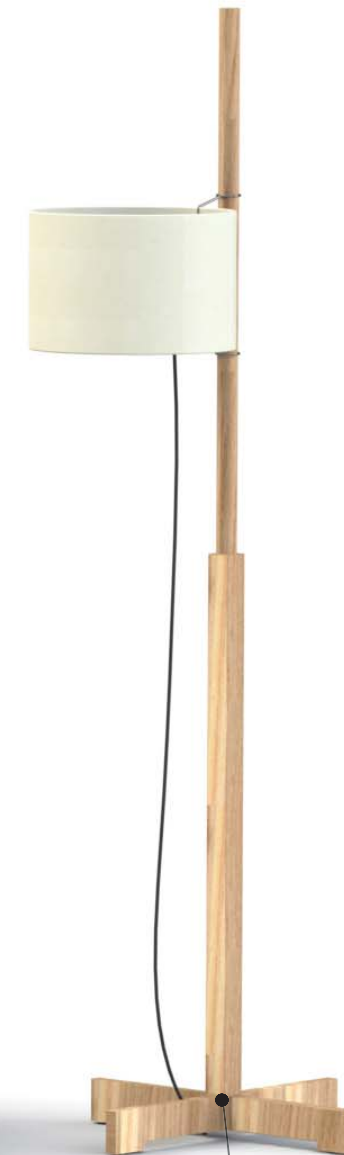

PURCHASED FLOOR LAMP WITH FABRIC SHADE AND WOOD FRAME

CHAISE AND SIDE TABLE DESIGN



SUITE LAYOUTS 9M-3RD FLOOR - FURNITURE CONCEPT



DESK ARMCHAIR WITH WOOD FRAME AND LEATHER UPHOLSTERY.

DESK ARMCHAIR LEATHER AND WOOD FINISHES

DESK LAMP IN BLACK FINISH

MATERIAL SWATCHES



STONE



TYPICAL DISTRESSED BLACK METAL



WHITE STAINED WOOD

DESK & BAR DESIGN



SUITE LAYOUTS 9M-3RD FLOOR - FURNITURE CONCEPT



MATERIAL SWATCHES



WHITE STAINED WOOD



TYPICAL DISTRESSED BLACK METAL

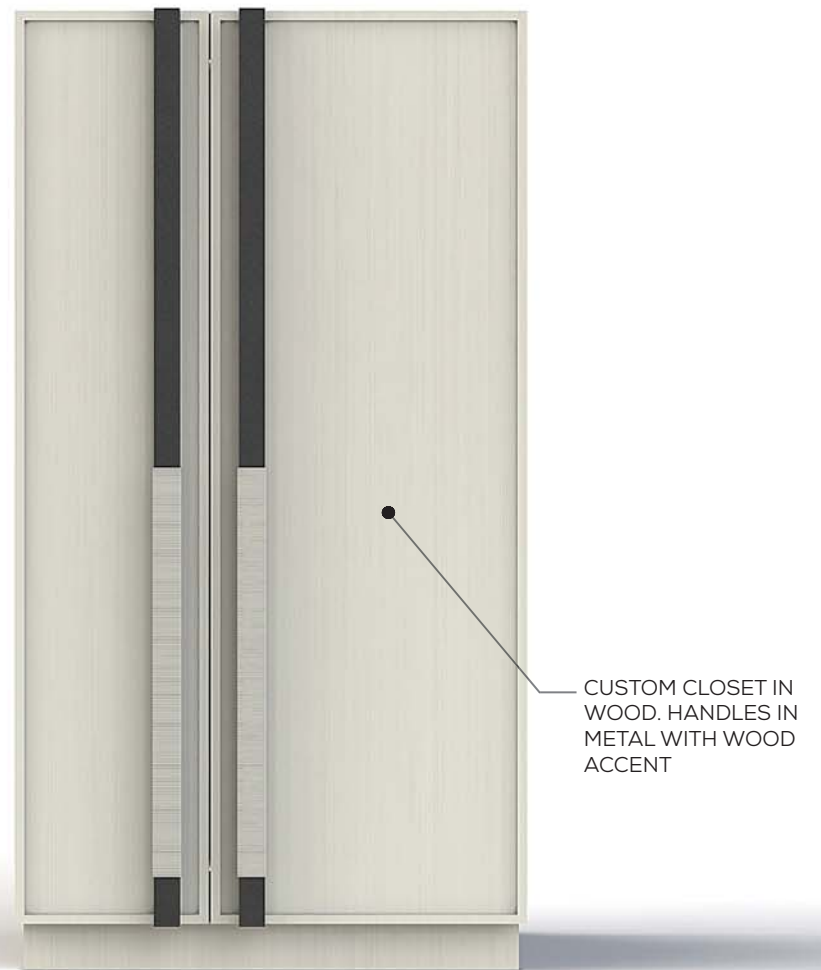

MATERIAL SWATCHES



WHITE STAINED WOOD



TYPICAL DISTRESSED BLACK METAL

SUITE LAYOUTS 9M-3RD FLOOR - FURNITURE CONCEPT



OUTDOOR SOFA



OUTDOOR LOUNGE CHAIRS



OUTDOOR TEAK SIDE TABLES



OUTDOOR COFFEE TABLE



OUTDOOR PLANTER DIRECTION

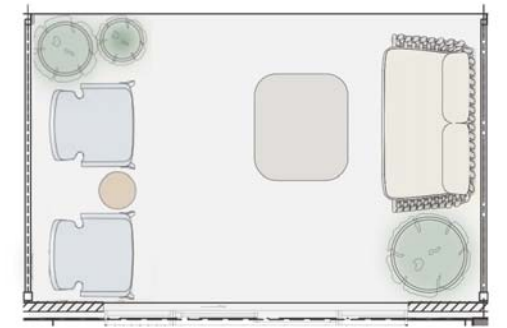

MATERIAL SWATCHES



SOFA FABRICS

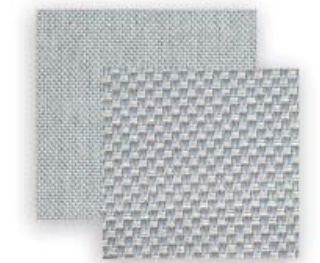

LOUNGE CHAIR FABRICS



FURNITURE FRAME FINISHES



TEAK

OUTDOOR FURNITURE

SUITE LAYOUT 9M BATHROOM-3RD FLOOR BATHROOM ELEVATIONS

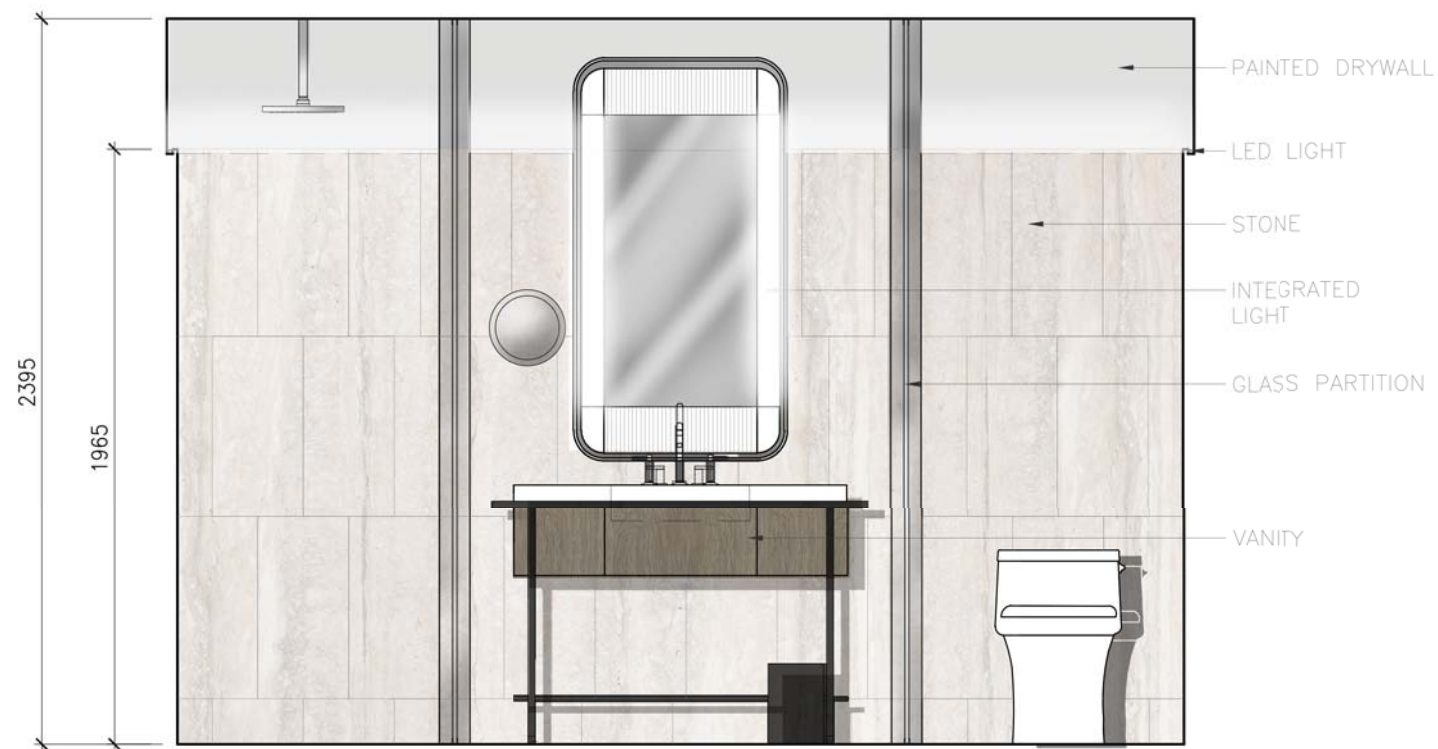
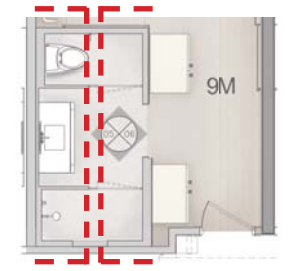

ELEVATION 5

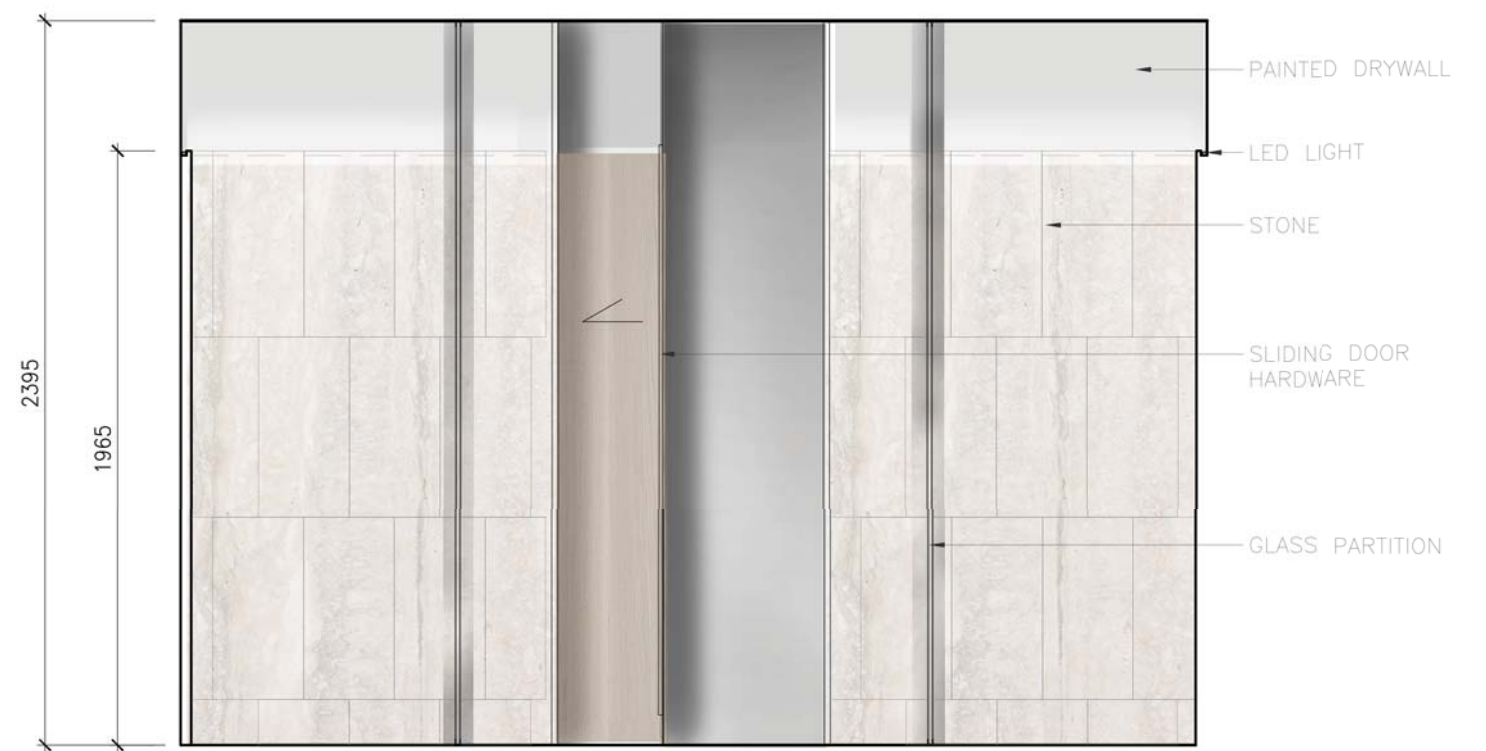

ELEVATION 6

SUITE BATHROOM PLUMBING SELECTION



DECK MOUNTED FAUCET



SHOWER HEAD



GRAB BAR



FLOOR MOUNTED TOILET



SHOWER DIVERTER



VALVE



HAND SHOWER



WALL HOOK

TYPICAL CORRIDOR

SUITE LAYOUT ELEVATOR LOBBY

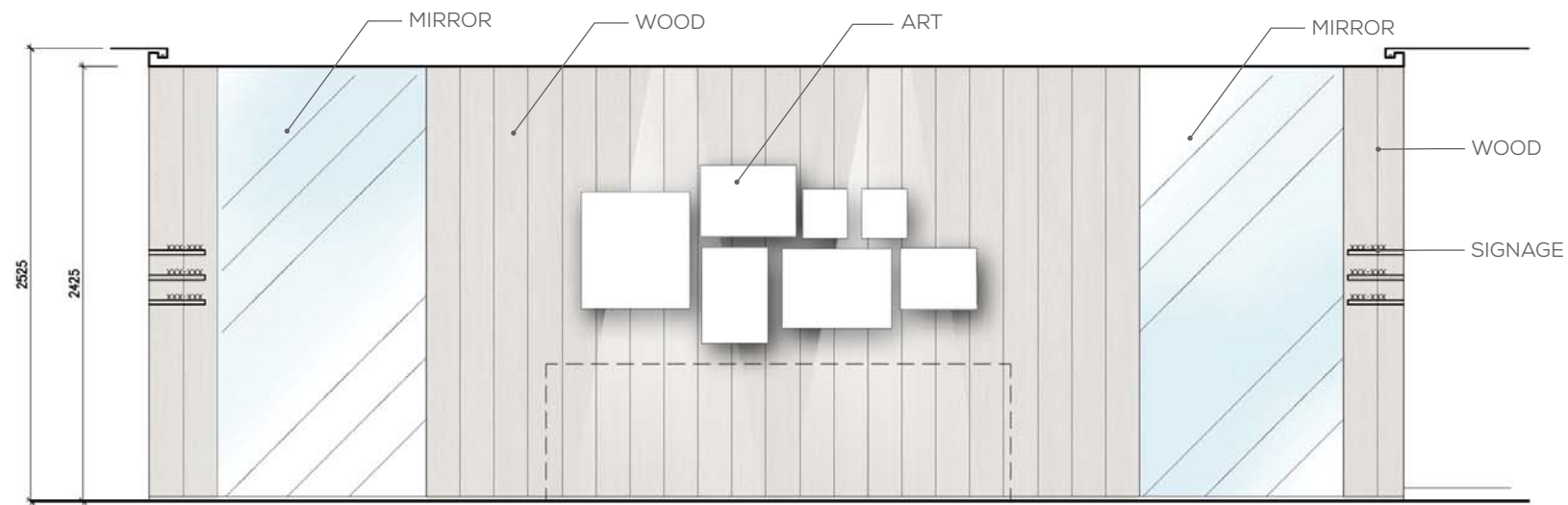
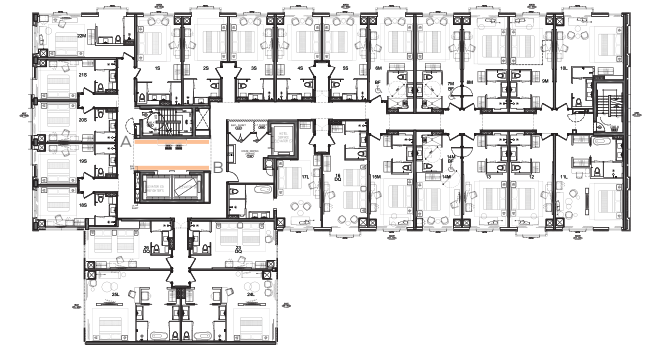

ELEVATION A

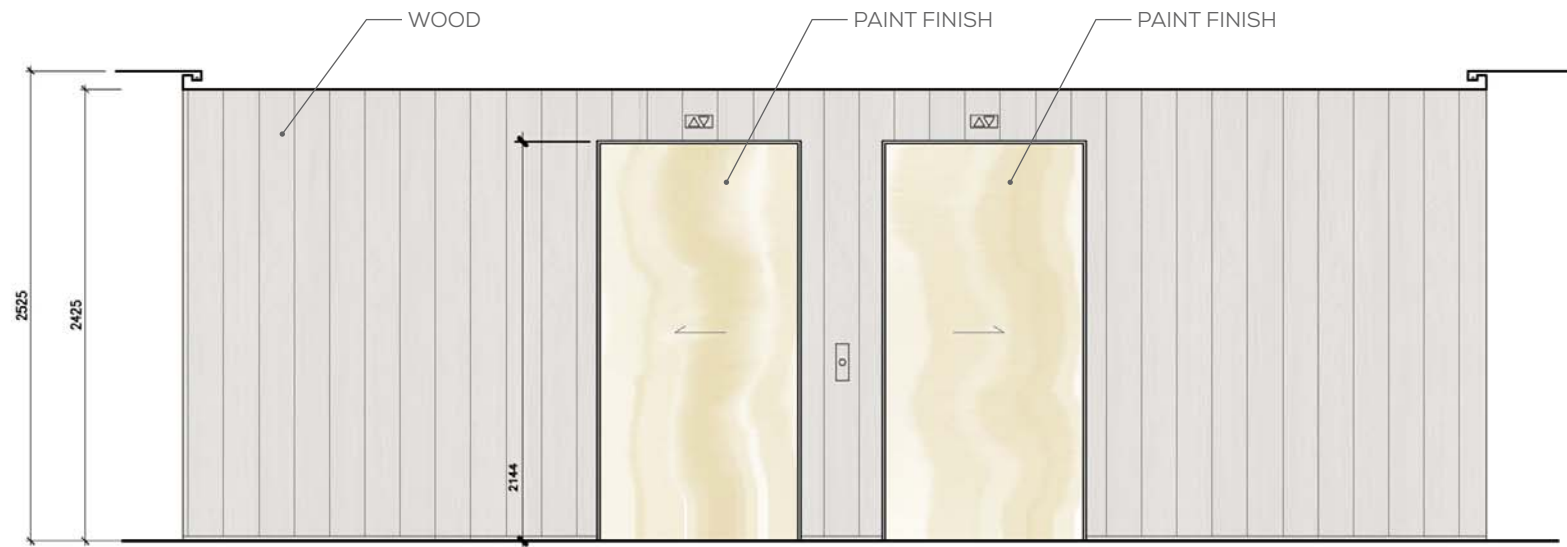

ELEVATION B

SUITE LAYOUT TYPICAL CORRIDOR

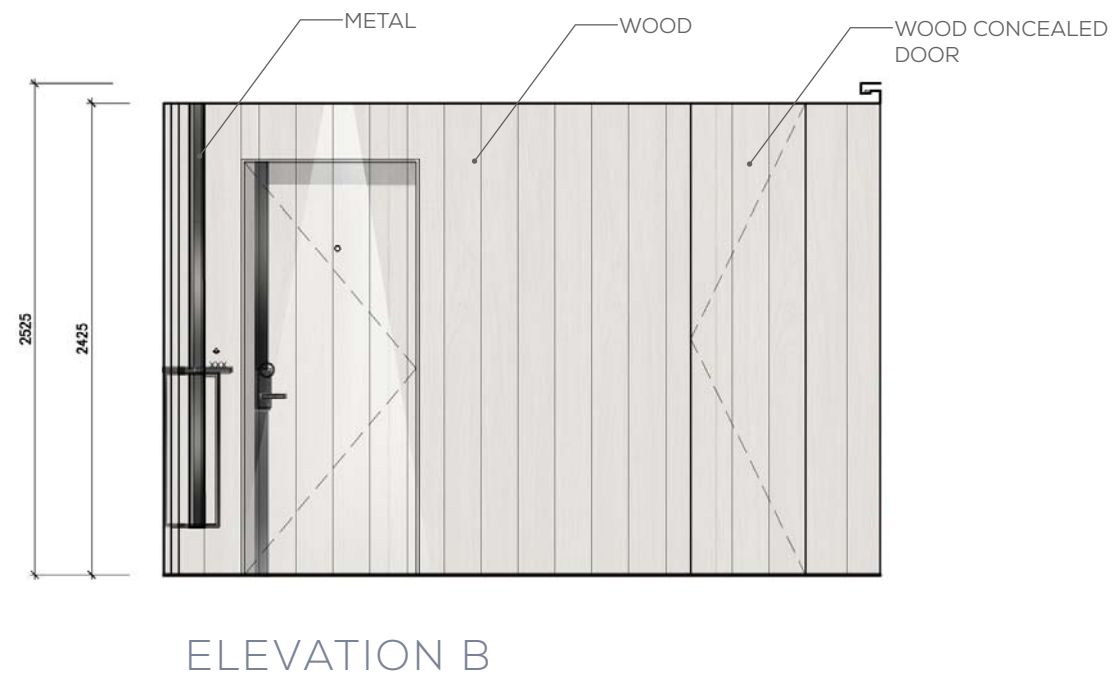
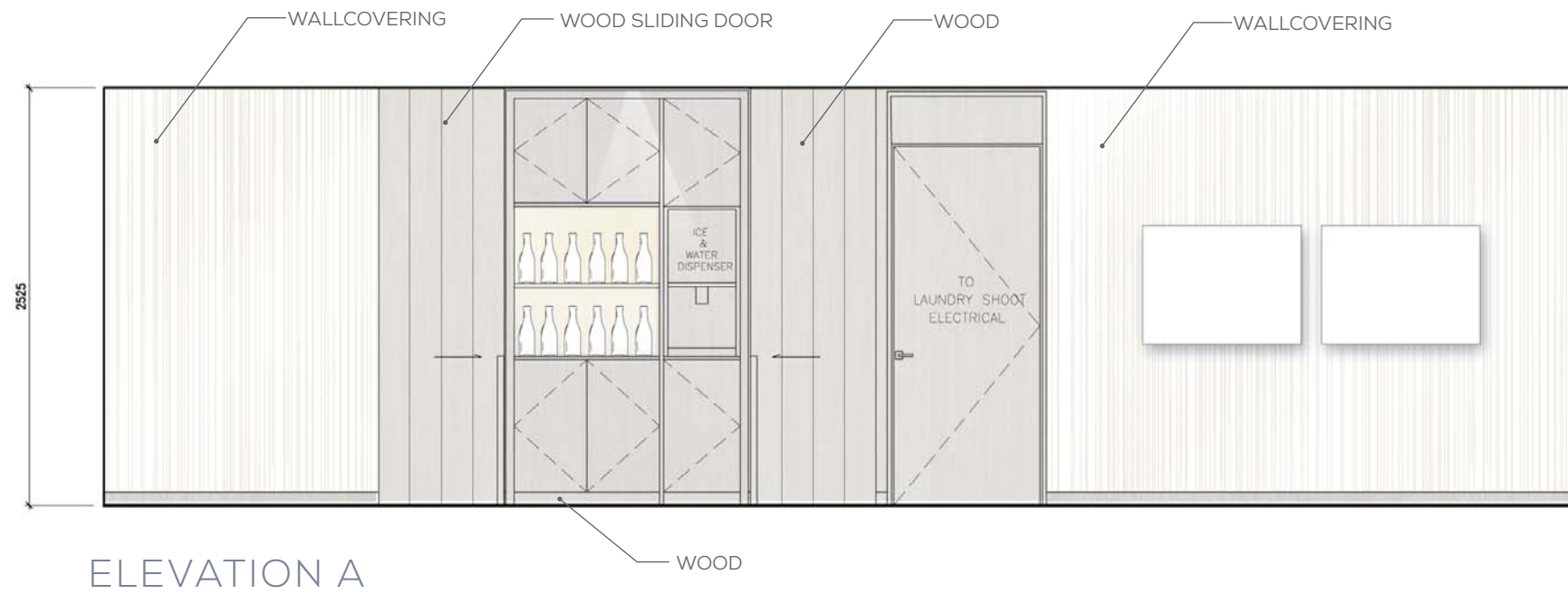
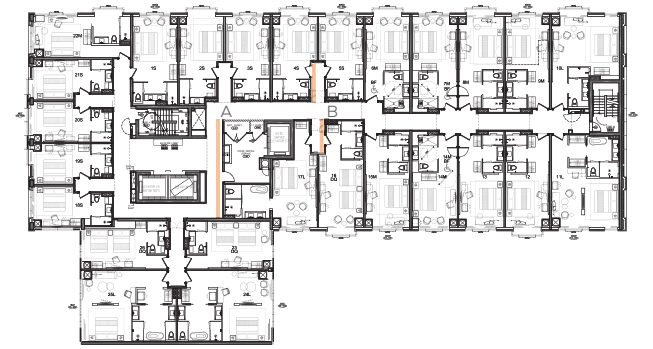

SUITE LAYOUT TYPICAL CORRIDOR

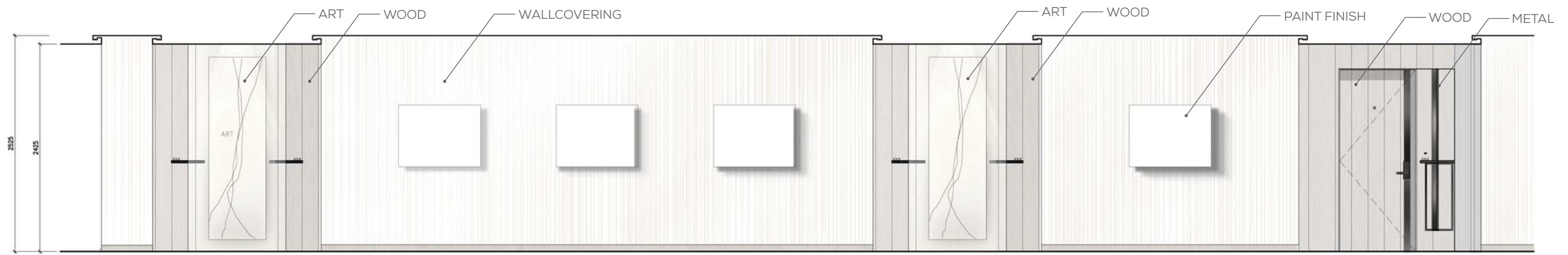
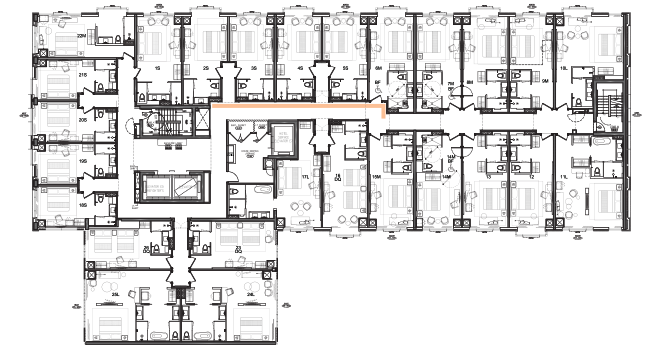

ELEVATION

SUITE LAYOUT TYPICAL CORRIDOR

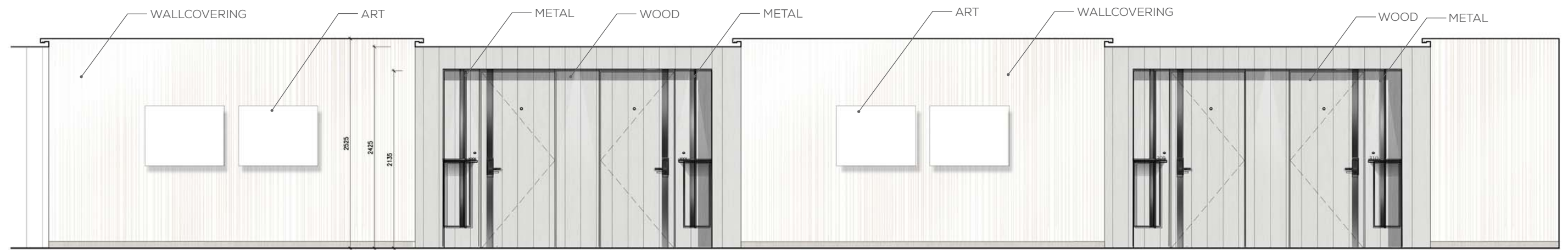
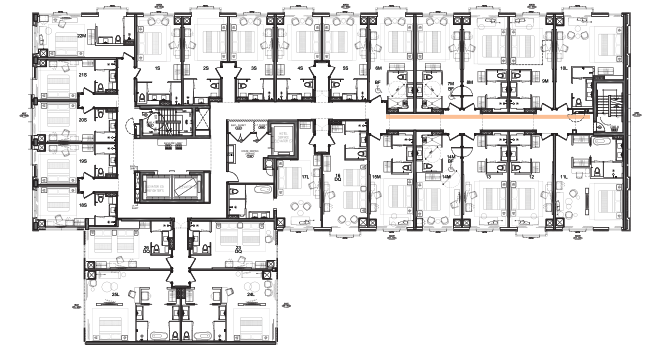

ELEVATION

SUITE LAYOUT TYPICAL CORRIDOR

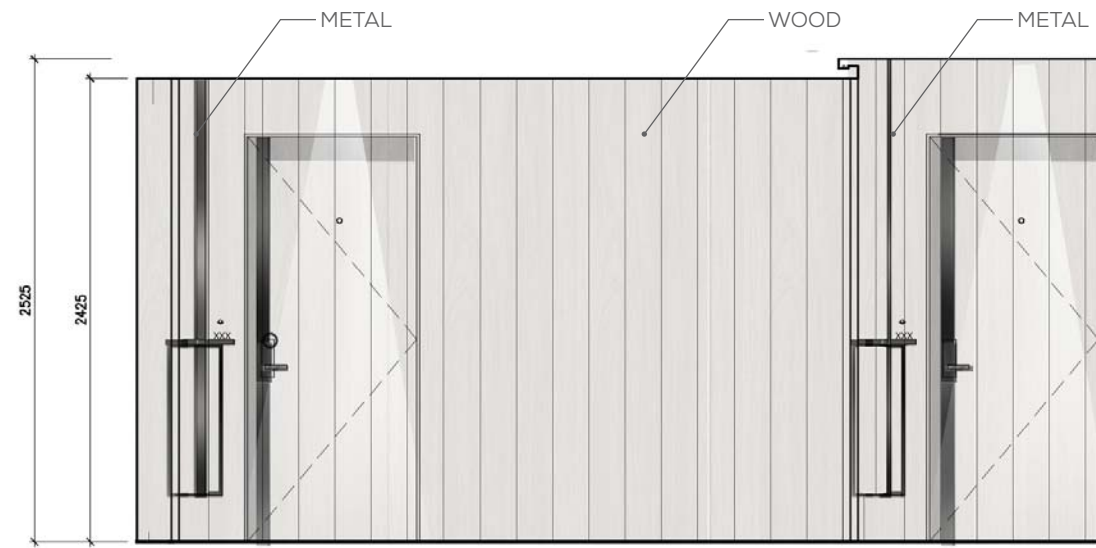

ELEVATION A



ELEVATION B

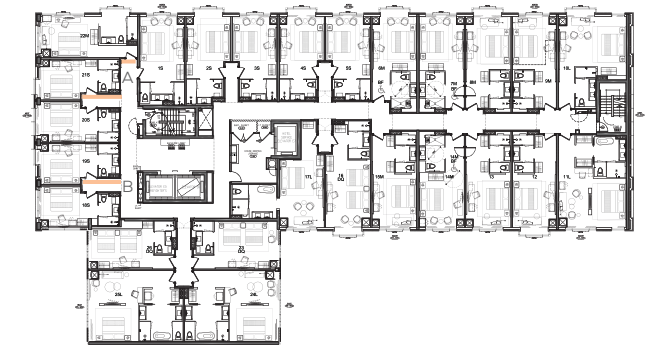

SUITE LAYOUT TYPICAL CORRIDOR

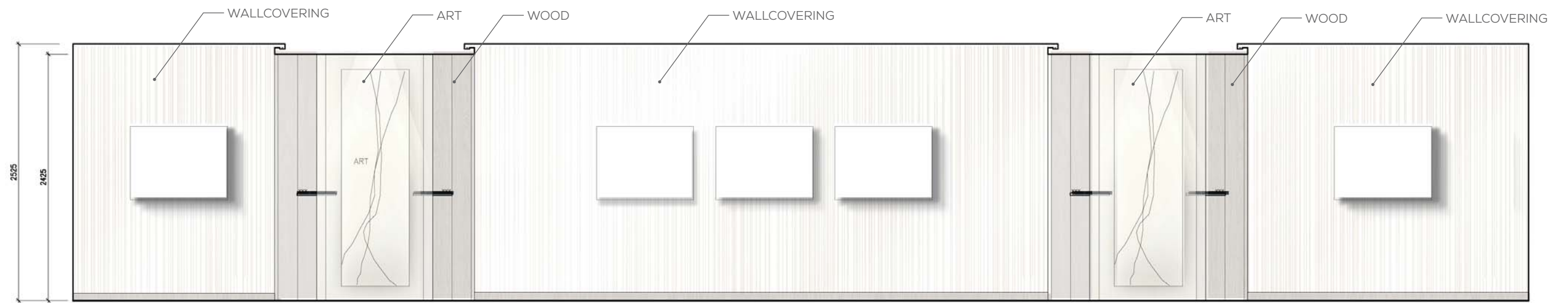
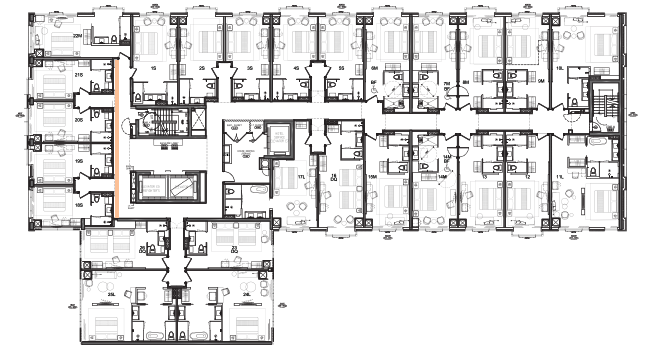

ELEVATION



SUITE LAYOUT TYPICAL CORRIDOR

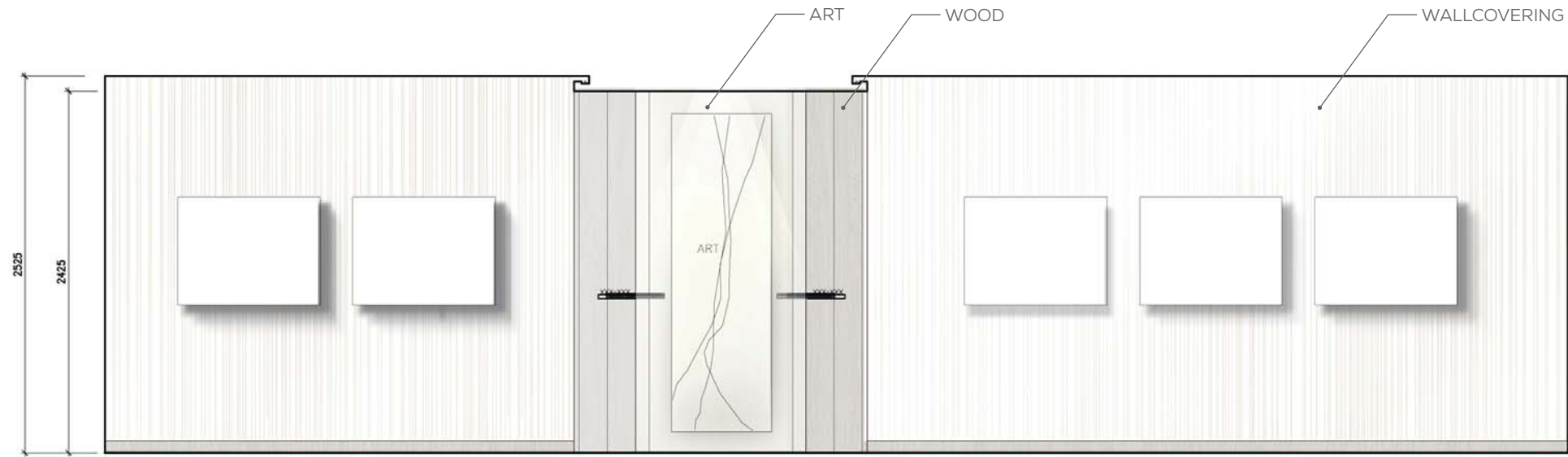
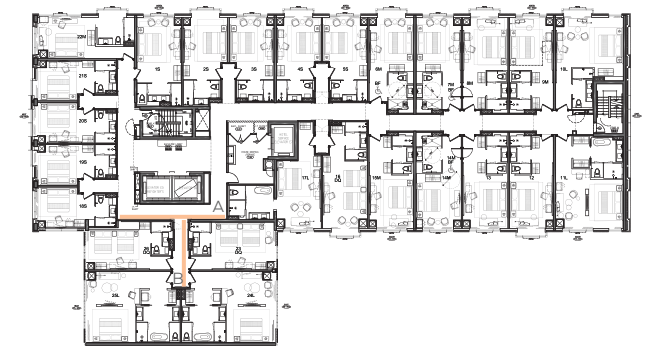

ELEVATION A



ELEVATION B

THANK YOU

